

# OPERATOR'S MANUAL 11L

(Combined EPA/CARB & EU)





**WARNING!** Operating, servicing and maintaining an engine can expose you chemicals including engine exhaust, carbon monoxide, phthalates, and lead which are known to the State of California to cause cancer and birth defects or other reproductive harm.

Breathing diesel engine exhaust exposes you to chemicals known to the State of California to cause cancer and birth defects or other reproductive harm.

To minimize exposure, avoid breathing exhaust when operating, servicing and maintaining the engine.

- Always start and operate the engine in a well-ventilated area.
- If in an enclosed area, vent the exhaust to the outside.
- Wear gloves or wash your hands frequently when servicing the vessel.
- Do not modify or tamper with the exhaust system.
- Do not idle the engine except as necessary.

For more information go to

**[www.P65warnings.ca.gov](http://www.P65warnings.ca.gov)**

**[www.p65warnings.ca.gov/products/diesel](http://www.p65warnings.ca.gov/products/diesel)**

# Table of Content

<b>Foreword</b> .....	3
<b>Safety Information</b> .....	4
<b>Introduction</b> .....	14
Fuel, oils and coolant .....	15
Maintenance and replacement parts .....	16
Excessive strain on a product and components .....	16
Environmental care .....	17
Emission Aftertreatment System .....	19
Volvo Penta Dealer Network .....	20
Volvo Penta Action Service .....	21
<b>Presentation</b> .....	22
<b>Engines</b> .....	22
<b>EMS (Engine Management System)</b> .....	23
<b>EATS (Exhaust Aftertreatment System)</b> .....	24
Overview .....	25
Operation .....	28
<b>Instruments and Controls</b> .....	30
DCU II (Display Control Unit) .....	30
<b>Starting</b> .....	34
<b>Before Starting</b> .....	34
<b>Starting the Engine</b> .....	35
DCU II (Display Control Unit) .....	35
Starting in Extreme Cold .....	35
Never Use Start Spray .....	36
Starting Using Auxiliary Batteries .....	36
<b>Operation</b> .....	37
<b>Reading the Instruments</b> .....	37
<b>Alarms</b> .....	37
<b>Maneuvering</b> .....	38
Operation at low load .....	38
<b>Engine Shutdown</b> .....	40
<b>Before Engine Shutdown</b> .....	40
<b>Stop the Engine</b> .....	40
Auxiliary Stop .....	41
<b>After Engine Shutdown</b> .....	41
<b>Fault handling</b> .....	42
Diagnostic Function .....	42
DCU II (Display Control Unit) .....	42
Erasing fault codes .....	43
<b>Fault Tracing</b> .....	44
<b>EATS Warnings and Inducements</b> .....	46
Warning Symbols .....	46
Quality shortcomings and component defects .....	47
EATS Inducements .....	48
<b>Fault Code Register</b> .....	49
<b>Maintenance Schedule</b> .....	52
<b>Maintenance</b> .....	53
<b>Orientation</b> .....	54
<b>Engine, General</b> .....	55
Air Filter, Check and Replace .....	55

Charge Air Pipe, Leakage Check .....	56
Drive Belt and Alternator Belt, Inspection .....	56
Drive belt, change .....	57
Alternator Belt, Replace .....	58
<b>Lubrication System</b> .....	58
Oil level, checking and topping up .....	59
Engine Oil, Change .....	59
Oil Filter/By-pass Filter, Change .....	60
<b>Fuel System</b> .....	61
Draining condensate, fuel system .....	61
Engine Fuel Filter Replacement .....	62
Fuel Pre-filter, Change .....	63
Fuel system, bleeding .....	64
<b>Cooling System</b> .....	66
Coolant Level, Checking and Topping Up .....	67
Coolant, Draining .....	68
Charge Air Cooler, External Cleaning .....	68
Cooling System, Cleaning .....	69
<b>Inlet and Exhaust System</b> .....	71
Filling AdBlue®/DEF .....	71
AdBlue/DEF-Pump Filter, Change .....	74
<b>Electrical System</b> .....	77
Main switch .....	77
Electrical Connections .....	77
Battery .....	78
<b>Storage</b> .....	80
<b>Technical Data</b> .....	82
Engines .....	82
<b>Lubrication System</b> .....	83
Viscosity .....	83
<b>Fuel System</b> .....	84
<b>Cooling System</b> .....	86
Coolant, Mixing .....	86
Water Quality .....	87
<b>Inlet and Exhaust System</b> .....	87
<b>Electrical System</b> .....	87
<b>Identification Numbers</b> .....	88
<b>Index</b> .....	91

# Foreword

## Welcome!

Volvo Penta engines are designed to fulfill Volvo's core values; quality, safety and environmental care. After more than 100 years as an engine manufacturer, the Volvo Penta brand has also become a symbol of reliability, technical innovation, top-of-the-range performance and long service life. Volvo Penta engines are used all over the world, in all possible operating conditions.

Make sure to thoroughly read through the Operator's Manual regarding operating and maintenance. It contains the information you need to be able to operate and maintain the engine safely and correctly. Pay careful attention to the safety instructions included in the manual.

As the owner of a Volvo Penta engine, you become part of a worldwide network of dealers and service workshop that assist you with technical advice, service requirements and replacement parts. Contact your nearest authorized Volvo Penta dealer for assistance.

It is possible to buy additional literature about your Volvo Penta engine, e. g. the Service & Maintenance manual. More information on how to do this can be found at [www.volvopenta.com](http://www.volvopenta.com).

**Information about your closest Volvo Penta dealer and other useful news and information can be found at [www.volvopenta.com](http://www.volvopenta.com) and by following Volvo Penta on Facebook.**

**VOLVO  
PENTA**

[www.volvopenta.com](http://www.volvopenta.com)



[www.facebook.com/volvopenta](http://www.facebook.com/volvopenta)

# Safety Information

This chapter describes how safety precautions are presented in the manual and on the product. Read the chapter through very carefully before you start the engine or do any maintenance or service. It has to do with your safety; an incorrect operation can lead to personal injury and damage to products or property. It also gives you an introduction to the basic safety rules for using and looking after the engine.

If anything remains unclear or if you are unsure of something, contact your Volvo Penta dealer for assistance.

## **IMPORTANT:**

Always follow local safety instructions and regulations.

### **Safety texts have the following order of priority:**

#### **DANGER!**

Indicates a hazardous situation, which, if not avoided, result in death or serious injury.

#### **WARNING!**

Indicates a hazardous situation, which, if not avoided, could result in death or serious personal injury.

#### **CAUTION!**

Indicates a hazardous situation, which, if not avoided, could result in minor or moderate personal injury.

#### **IMPORTANT:**

Indicates a situation, which, if not avoided, could result in property damage.

**NOTICE!** Used to draw attention to important information that facilitates work or operations.



This symbol is may be used on the product to call your attention to the fact that this is safety information. Always read such information very carefully.

Make sure that warning and information symbols on the engine are clearly visible and legible. Replace symbols that have been damaged or have been painted over.



In some cases, this symbol is used on our products and refers to important information in the Operator's Manual.

Most chemicals such as engine and transmission oils, glycol, petrol and diesel oil and chemicals used in workshops such as degreasing agents, paint and solvents are harmful to health.

Carefully read the instructions on the product packaging! Always follow the safety regulations, such as the use of protective masks, goggles, gloves, etc. Make sure that other personnel are not exposed to substances that are hazardous to health. Ensure good ventilation.

Manage used and leftover chemicals in the prescribed manner.

## Daily Checks

### **▲ WARNING!**

Do not start the engine if there is reason to suspect fuel leaks or if there is explosive material nearby.

Make it a habit to give the engine and engine compartment a visual check before the engine is started and after operations, once the engine has stopped. This helps you to quickly discover fuel, coolant or oil leakages or any other abnormality that has occurred, or is about to occur.

## Personal safety equipment

### **▲ CAUTION!**

Always use appropriate safety equipment. Personal protective equipment does not eliminate the risk of injury but it will reduce the degree of injury if an accident does happen.

Some examples are ear protection, eye and face protection, protective footwear, personal protective equipment, head protection, protective clothing, gloves and respirators.

### **▲ WARNING!**

Ensure that all machine guards and safety devices are in place and are functional.

### **▲ CAUTION!**

Never use tools or products that show signs of damage.



P0024482

## Protect your eyes

### ⚠ CAUTION!

Wear safety glasses.

Always wear safety glasses if there is a risk of splintering, sparks and spray from the electrolyte (so-called battery acid), or other chemicals. Your eyes are very delicate and damage can result in loss of sight!

## Protect your skin

### ⚠ CAUTION!

Risk of skin damage.

Avoid getting oil on your skin! Prolonged or repeated exposure to oil can dry out the skin. Thereafter, irritation, dryness and eczema and other skin problems may occur.

Use protective gloves and avoid oil-soaked clothes and rags. Wash regularly, especially before eating. Wear suitable protective creams to prevent skin from drying out and to facilitate cleaning.

## Fire safety

### ⚠ WARNING!

Fire and Explosion Risk!

Accidental spark could ignite fuel vapors.

All fuels – as well as many lubricants and chemicals – are flammable. Do not allow open flames or sparks near them. **Smoking forbidden!** Hydrogen from the batteries is also very flammable and explosive in certain mixture with air.

Ensure that the workplace is well ventilated and take the necessary precautions before welding or grinding begins. Always ensure that there is a fire extinguisher close at hand in the work area.



P0024470



## Spare parts — safety

### **▲ WARNING!**

Always use spare parts with the same quality as genuine Volvo Penta parts to minimize the risk of an explosion or fire.

Components in fuel systems and electrical systems on Volvo Penta engines are designed and manufactured to minimize the risk of explosions and fire, in accordance with applicable legal requirements.

## Used oils, filters and chemicals etc.

### **▲ WARNING!**

Risk of fire.

Store fuel soaked rags and other flammable material so that there is no danger of them catching fire.

Oil-soaked rags can spontaneously ignite under certain circumstances.

### **IMPORTANT:**

Used fuel and oil filters are environmentally hazardous waste and must be taken to an approved waste management facility for correct handling, as must any used lubricating oil, contaminated fuel, paint residue, solvents, degreasers and wash residue.

## Prevent start of the engine

### **▲ WARNING!**

Immobilize the engine by turning off the power supply with the main switch(es) and lock it (them) in the off position before starting work. Place a warning notice at the main switch.

If the engine is equipped with BMS (Battery Management System), always disconnect both battery cables from the battery terminals.

## Ventilation when running the engine

### **▲ WARNING!**

Only start the engine in a well-ventilated area. If operating the engine in a closed area ensure that there is exhaust ventilation leading out of the work area to remove exhaust gases and crankcase ventilation emissions.

The engine must not be operated in areas where there are explosive materials or stored gas.



P0024481



P0024808

## Rotating parts and hot surfaces

### **⚠ DANGER!**

Working with or approaching a running engine is a safety risk. Watch out for rotating components and hot surfaces.

If the engine is in operation and operates another device, you must not, under any circumstances, staying close to the engine.

Work on running engines is strictly prohibited. There are however adjustments that require the engine to be run. Approaching a running engine is a safety risk. Loose clothing and long hair can get caught in the rotating parts; careless movements or a dropped tool can lead to serious personal injury.

Be careful to avoid hot surfaces (exhaust pipes, turbochargers, charge air manifolds, start elements etc.) and hot fluids in pipes and hoses on engines that are running or have just stopped. Re-install all protective covers that were removed during maintenance work before starting the engine.

## Information on the engine

### **IMPORTANT:**

Make sure that all warning and information decals on the product are always visible. Replace decals which have been damaged or painted over.



P0024483

## Prohibition on use of start spray

### **⚠ WARNING!**

Never use start spray or similar agents to start an engine. This may cause an explosion in the inlet manifold. Risk of personal injury.



P0024688

## Before start of engine

### **⚠ WARNING!**

Never start the engine if there is reason to suspect fuel and/or gas leaks, or if there is explosive material nearby.

### **IMPORTANT:**

Only start the engine with the air filter and protective caps fitted. Foreign objects in the inlet line could cause machine damage. Also make sure that no tools or other parts have been left next to the engine.

### **⚠ WARNING!**

Never start the engine with the valve cover removed. There is a risk of personal injury. For engines with turbochargers, the rotating compressor turbine can in addition cause serious personal injuries.

## Before any work on the electrical system

### **⚠ WARNING!**

Always stop the engine first. Then disconnect the current at the main switches and any external power supply before working on the electrical system – to minimize the risk of electrical hazards.

### **IMPORTANT:**

Never disconnect the current using the main switches when the engine is running or by disconnecting the battery cables. The alternator and electronics could be damaged.

## Avoid damage to the engine control module and other electronics

### **IMPORTANT:**

Switch off the main switch before connecting or disconnecting a connector.

## Before welding work

### **IMPORTANT:**

Before any work with electric weld can begin, the connection to all control units must be disconnected. After finished welding, re-connect the connection to all control units before connecting any battery cable.

## Before any work on the cooling system

### **⚠ WARNING!**

Stop the engine and let it cool before starting work on the cooling system. Hot fluids and hot surfaces can cause burns.

## Hot coolant under pressure

### **⚠ CAUTION!**

Hot coolant can cause burns. Avoid opening the filler cap for the coolant when the engine is still hot. Steam or hot coolant can spray out and system pressure is lost.

Open the filler cap slowly and release the pressure in the cooling system if the filler cap or valve must be opened – or if a plug or a coolant hose must be removed from a hot engine.

## Hot oil under pressure

### **⚠ CAUTION!**

Hot oil can cause burns. Avoid getting hot oil on the skin. Ensure that the lubrication system is not pressurized before starting any work. Never start or operate the engine without the oil filler cap is on. There is a risk that hot oil can spray out.

## Refueling

### **⚠ WARNING!**

There is always a risk of fire and explosion during refueling. Smoking is forbidden and the engine must be stopped.

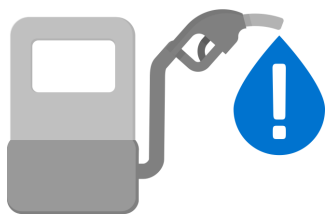

P0024477

## Proper fuel quality

### IMPORTANT:

Always use the fuel recommended by Volvo Penta. See *Technical Data* in Operator's Manual. Other fuel can damage the engine. Wrong fuel quality can also lead to higher service costs.

### ⚠ WARNING!

Risk of personal injury. Wrong fuel quality in a diesel engine can cause the fuel control mechanism to bind which can cause the engine to overspeed!

## Legal requirements to use proper fuel

### IMPORTANT:

To meet regulatory requirements for certified emission levels must always recommended fuel according to *Technical Data* in the Operator's Manual be used.



P0024488

## At any leak detection on the fuel system

### ⚠ WARNING!

Wear safety goggles! Be extremely careful when searching for leaks in the fuel system high-pressure circuits. There is very high pressure in the jet from pipes and injectors. The fuel may penetrate the tissue and cause serious risk of blood infection (septicemia).

## Handling of fuel pipes

### IMPORTANT:

High pressure pipes for fuel must not be bent or straightened under any circumstances. Cracks may occur. Damaged pipes must be replaced.

## Safe handling of batteries

### ⚠ WARNING!

Risk of fire and explosion. Never allow an open flame or electric sparks near the batteries.

A spark caused by an incorrectly connected battery can be enough for the battery to explode with serious injuries.

Do not touch the connections during start attempts. Sparking hazard! Do not lean over batteries.

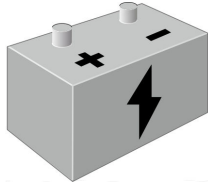

P0024468

## Correct polarity of the batteries

### IMPORTANT:

Make sure that the positive (+) and negative (-) battery cables are correctly connected to the corresponding battery terminals. Wrong connection may cause severe damage to electrical equipment.

## Risks of electrolyte in batteries

### ⚠ WARNING!

Always wear protective goggles when charging or handling batteries.

Battery electrolyte is highly corrosive.

Rinse immediately with copious amounts of water if the electrolyte gets in your eyes. Search directly after the rinsing help by medical staff.

If it comes electrolyte to unprotected skin, wash immediately with soap and water.

## Layout of the battery compartment

### IMPORTANT:

Make sure the battery compartment is designed according to current safety standards.

## Cleaning the engine and components

### IMPORTANT:

Never use a high pressure washer for cleaning of engine or engine components.



P0024486

## Cleanliness for sensitive components

### **IMPORTANT:**

Observe meticulous cleanliness when handling system components. Even minimal amounts of dirt could cause a breakdown.

## Adjustment of the clutch

### **⚠ CAUTION!**

Clutch adjustments must be carried out with the engine stopped.

# Introduction

**Check that you have received the correct operator's manual before continuing reading. If not, please contact your Volvo Penta dealer.** Read the Operator's Manual carefully and learn to handle the engine, controls and other equipment in a safe manner before you start the engine.

For engine designations, refer to *Engine*. The designation is stated on the engine plate, refer to *Identification Numbers*.

The illustrations in this book may cover several product types, which means that there may be slight differences between the illustrations and the purchased product. This does, however, not affect the validity of the information and/or instructions in the manual. Volvo Penta reserves the right to make alterations to specifications, design features, and illustrations without prior notice.

At service, software can be updated that affects the functionality described in this manual.

## About this manual

This Operator's Manual contains the information required for the correct, safe operation and maintenance of your Volvo Penta engine. Read the Operator's manual carefully and learn to handle the engine and other equipment in a safe manner before you start the engine.

## Warranty

Your new Volvo Penta engine is covered by a limited warranty, subject to the conditions compiled in the Warranty Information. Note that AB Volvo Penta's liability is limited to the specification in the Warranty Information (included CD) and Emission Control System Warranty Statement.

Read the information carefully, as soon as possible after delivery. It includes important information about service and maintenance; the owner is responsible for being familiar with, checking and implementing these. Otherwise AB Volvo Penta may deny its warranty obligations in part or in full.

**Contact your Volvo Penta dealer if you have not received the Warranty Information or Service Book.**



## Running in the engine

### **The engine must be run in during its first 10 operating hours, as follows:**

Run the engine in normal operations. However, full load may not be applied other than for short periods. Never run the engine for long stretches at constant speeds during this period.

Higher oil consumption is normal during the first 100–200 hours of operation. For this reason, check the oil level more frequently than the normal recommendation.

When a disengageable clutch is installed, it should be checked more carefully during the first days. Adjustments may be necessary to compensate bedding-in of the friction plates.

## Fuel, oils and coolant

Only use the fuels and oils recommended in the Operator's Manual, since other grades may cause malfunctions, increased fuel consumption, and possibly shorten the life of the engine.

Always change the oil, oil filters, and fuel filter at the specified maintenance intervals.

Make sure to always use suitable and correctly mixed coolant.

Future warranty claims related to engine and accessories may be denied if an unsuitable coolant has been used, or if the instructions for coolant mixture have not been followed.

## Maintenance and replacement parts

Volvo Penta engines are designed for maximum reliability and long life and built to withstand a demanding environment. The engines also are designed to have a minimal environmental impact. These qualities will be maintained through regular servicing and the use of spare parts with the same quality as genuine Volvo Penta parts. If reliable and purpose-built parts are not used, your safety, health, and the machine's function may be compromised. Volvo Penta has a world-wide network of authorized dealers.

The authorized dealers are Volvo Penta product specialists, and have the accessories, genuine parts, test equipment and special tools needed for high quality service and repair work. Always observe the maintenance intervals in the manual, the complete Service Protocol can be found at [volvopenta.com](http://volvopenta.com). Remember to note the engine / transmission identification number when you **order service and spare parts**.

## Excessive strain on a product and components

Volvo Penta products and components are not dimensioned for external loads. Never stand or step onto an engine, transmission or its components. Loads can bring about damage and the malfunction of a product or property.

## Environmental care

Environmental care is a core value at Volvo Penta. Energy efficiency and low emissions are among the most important product related aspects and priority focus areas for Volvo Penta business. Several of the global challenges the world faces are directly or indirectly related to power industries and transports. We recognize that Volvo Penta is part of the environmental problems, but we are also convinced that we are a part of the solution.

Volvo Penta currently has a broad engine program in which great advances have been made in reducing exhaust emissions in the same time as the fuel consumption has been improved. Through regular maintenance, the Volvo Penta engines retain its low fuel consumption and low emissions. We hope that you will be keen to preserve these qualities.

Always follow the directions in the Operator's Manual regarding fuel grades, operation and maintenance to avoid unnecessary environmental impact. Contact your Volvo Penta dealer if you notice any changes such as increased fuel consumption or exhaust smoke.

Remember always to hand in environmental hazardous waste such as drained oil, coolant, old batteries, etc. for treatment at a recycling facility. Our united efforts can make a valuable contribution to the environment.

## Certified engines

**If you own an emission-certified engine used in an area where exhaust emissions are regulated by law, this places special demands on the care and maintenance you provide your engine.**

**NOTICE!** Neglects or failure to follow the points listed here may invalidate the engine emission certificate. This means AB Volvo Penta can no longer guarantee engine conformity with the certified model. Volvo Penta is not responsible for damages or costs arising as a result of this.

- Certification means that an engine type has been checked and approved by the relevant authority. The engine manufacturer guarantees that all engines of the same type are equivalent to the certified engine.
- It is the responsibility of the operator/user to ensure that no intentional misuse of the engine takes place.
- Volvo Penta maintenance and service intervals must be complied with.
- Any case of malfunction must be rectified without delay.
- Only use genuine Volvo Penta parts or spare parts with the same quality as genuine Volvo Penta parts.
- Volvo Penta recommends that service to injection pumps, pump settings and injectors always are carried out by a qualified workshop.
- The engine must not be converted or modified in any way, except with accessories and service kits that Volvo Penta has approved for the engine.
- No installation changes to the exhaust pipe and engine air inlet ducts may be made.
- No warranty seals (where present on the product) may be broken by unauthorized persons.
- The general instructions in the Operator's Manual concerning operation, service and maintenance apply.

## Emission Aftertreatment System

### AdBlue®/DEF

AdBlue®/DEF <sup>(1)(2)</sup> is mandatory for the equipment/ vehicle to comply with emission directive certification.

When adding AdBlue®/DEF, the solution must fulfill ISO22241 standards. If the solution used don't fulfill the ISO standard, any warranty claims will be rejected.

Using an engine that does not use AdBlue®/DEF, or the use of low quality solution, where such is required to reduce air pollution is a punishable offense. A consequence of such a failure may entail invalidation of conditions and warranties provided in the country where the engine is used.

Filling should take place between scheduled service intervals. The consumption of AdBlue/DEF is a percentage of the fuel consumption and is varying depending on the operating conditions. For filling instructions, refer to *Filling AdBlue®/DEF*, page 71.

If the exhaust gas control system does not work correctly the operator will be informed by a fault indication.

---

1. AdBlue® = Registered trademark of the Verband der Automobilindustrie e.V. (VDA ).

2. DEF = Diesel Exhaust Fluid

## **Volvo Penta Dealer Network**

The Volvo Penta global network of authorized dealers is at your service. We strongly recommend that you take your product to an authorized Volvo Penta dealer for service and repair. They are specialists in Volvo Penta products and have the accessories, genuine Volvo Penta parts, the special tools and the latest service information for high quality service and repair work.

### **Dealer Locator Services**

Locate the nearest Volvo Penta dealer through our dealer locator on **[www.volvopenta.com](http://www.volvopenta.com)** or download the dealer locator app to your smartphone.



## Volvo Penta Action Service

Our global dealer network, your first line of contact, is backed up by Volvo Penta Action Service, a phone based breakdown and support service providing assistance 24 hours a day, every day of the year.

### How it works

A dedicated operator will support you all the way through your case and keep you updated on status and progress.

Whenever on-site assistance or technical support is needed, the operator will put you in contact with the closest Volvo Penta dealer that can support your product.

### Phone numbers

Find your Volvo Penta Action Service phone number and more information on [www.volvopenta.com](http://www.volvopenta.com).

# Presentation

## Engines

This Operator's Manual covers the following engines:

TAD1170VE, TAD1171VE, TAD1172VE

They are in-line, six-cylinder, direct injection industrial diesel engines.

The engines are all equipped with electronic management (EMS), turbocharger, charge air cooler, a thermostatically controlled cooling system and electronic speed control.

In order to reduce emission levels the engines are equipped with EATS (Exhaust Aftertreatment System) and EGR (Exhaust Gas Recirculation).





## EMS (Engine Management System)

EMS is an electronic system with CAN communication (Controller Area Network) for diesel engine control. The system has been developed by Volvo Penta and includes fuel regulation and diagnostic functions. The system consists of a control unit, injectors, a number of sensors that supply the control unit with information, and connectors for diagnostics and functional checks. The engine can be connected to a communication interface comprising a CAN link and a serial link.

### Input/Output signals

The information from the sensors provides precise data about prevailing operating conditions and allows the processor in the control module to, among other things, calculate correct injection amount, injection timing and check the engine's condition.

### Fuel regulation

The engine fuel requirement is analyzed up to 100 times per second. The engine injection volume and injection timing are controlled electronically via the fuel valves in the injectors. The control unit receives signals from sensors and monitors in order to determine when the fuel valve must open and close. This means the engine always receives the correct fuel volume under all operating conditions, which means lower fuel consumption and the lowest possible exhaust emission.

### Diagnostic function

The purpose of the diagnostic function is to detect and locate any malfunctions in the EMS system, as well as to protect components from damage.

If a malfunction is detected, this is announced by warning lamps, a flashing diagnostic lamp or a text message on the instrument panel, depending on the equipment fitted. If a fault code is displayed it is used for guidance in any fault tracing. Fault codes can also be read by Volvo's VODIA tool at authorized Volvo Penta workshops.

If there is a serious malfunction, the engine will be shut down completely or the control unit may reduce power output (depending on the application). Fault codes are registered as an aid to fault tracing.

## EATS (Exhaust Aftertreatment System)

EATS (Exhaust Aftertreatment System) is used to reduce emissions. In the SCR-system (Selective Catalytic Reduction) the exhaust gases are treated through the addition of AdBlue<sup>®</sup>/DEF before they pass through the catalytic converter. Sensors measure nitrogen oxide (NOx) levels in the exhaust gases.

The engine control unit calculates the optimum amount of solution to be added in relation to engine load and engine speed, to achieve efficient reduction of nitrogen oxides.

### AdBlue<sup>®</sup>/DEF

The solution that is added to the exhaust gases is a clear, transparent liquid with a faint odor of ammonia; it consists of de-ionized water mixed with 32.5% urea (the solution must meet ISO 22241 standards / API AUS 32). The urea in the exhaust is broken down into ammonia which reacts with NOx to form harmless nitrogen and water vapor, which occur naturally in our surroundings.

The solution is not flammable or harmful to health with normal use; it is however very corrosive to metals, especially copper and aluminum.

#### **IMPORTANT:**

The use of solution that do not fulfill the ISO 22241 standard will compromise the aftertreatment system performance, increase emissions. Any warranty claims will be rejected.

**NOTICE!** The urea solution has different names in different markets, e.g. DEF or AdBlue<sup>®</sup>. The solution is designated either AdBlue or AdBlue/DEF in display messages.

### Monitoring

The system is monitored to ensure that all system components are working as they should, that the quality of the AdBlue<sup>®</sup>/DEF fulfills set standards and that the tank level is not too low. Should the system detect deviations, the maximum engine torque and engine speed will be reduced and a fault code stored in the control unit. For further information refer to *EATS Inducements, page 48*.

## Shut-down

Should any solution remain in the hoses in freezing weather, the entire system can be damaged. To avoid this and any solution spillage, the system is equipped with automatic drainage when the engine is switched off so that hoses, the pump and injector are emptied and the solution runs back to the tank.

**NOTICE!** The automatic drainage only works when the engine is stopped using the ignition switch or the stop button on the instrument panel (depending on application), not if only the engine power supply is disconnected. If the system is not drained properly, solution may squirt out if the hoses are disconnected.

### ⚠ CAUTION!

The EATS system needs time to for automatically drainage and depressurizing.

Wait at least two minutes after the engine been turned off before removing the AdBlue/DEF hoses.

## Overview

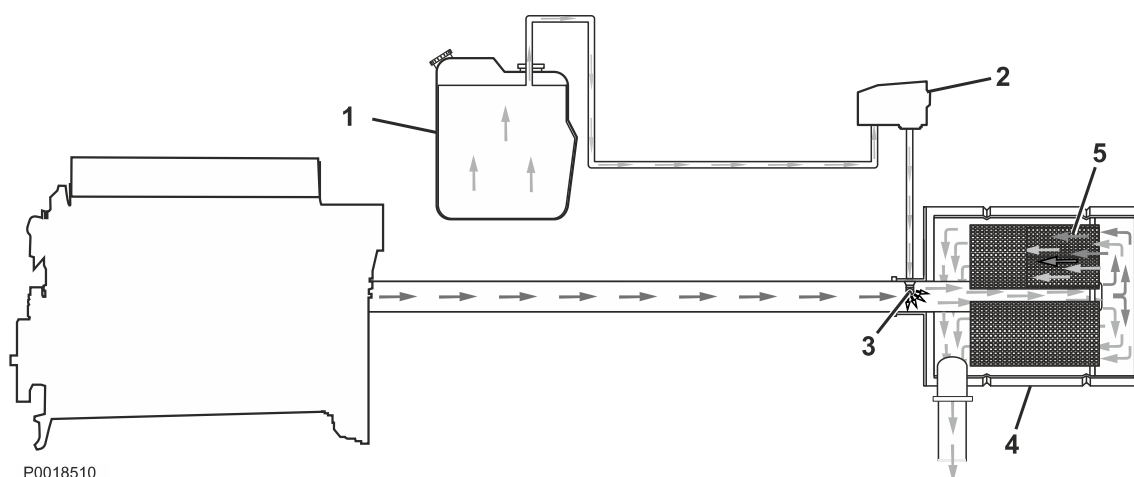

### The system comprises:

- 1 Tank
- 2 Pump
- 3 Injector
- 4 EATS Catalyst and Muffler
- 5 Catalytic Converter

The atomized AdBlue®/DEF is sprayed into the exhaust gases upstream of the catalytic converter.

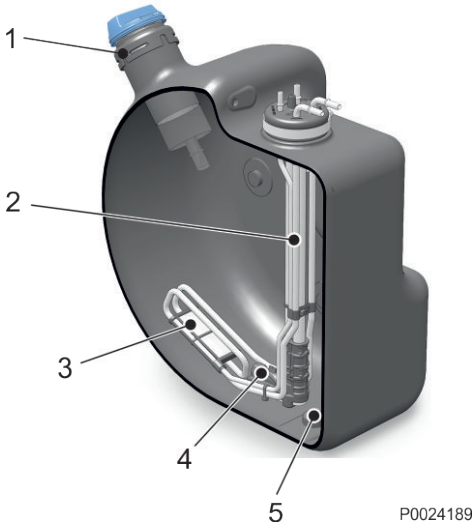

## AdBlue®/DEF Tank

### IMPORTANT:

Dirt/dust, oil, greases, detergents and any chemicals and natural products must be prevented from entering the Adblue/DEF tank.

The system will be damaged if dust or dirt enters the tank clogging the filters in the dosing system. Keep the tank clean at all times.

AdBlue®/DEF is stored in a separate tank. There is a fitting in the tank that comprises a heating coil (2), a filter (3) and a quality sensor (4). The filter on the suction line prevents any particles from circulating through the system and causing disruptions. The filter must be checked and cleaned as necessary.

There is a drain plug (5) on the bottom of the tank so that the solution can be emptied when necessary, e.g. for cleaning. The tank is fitted with a breather to equalize pressure changes.

The filler pipe (1) is equipped with a blue cap to prevent confusion when filling.

### Tank level

The solution consumption varies during operations. The level in the tank is shown on the gauge as a percentage of the total tank volume.

When the level in the tank falls below the set limit, the level sensor in the tank transmits a signal that stops AdBlue/DEF dosing. A fault code is set in the engine control unit, a warning lamp lights up and a fault message is shown on the control panel. If solution is not added, injection into the exhaust pipe will cease and engine torque and engine speed will be limited. When solution is added the fault message is canceled and the engine is able to revert to full power. Refer to *EATS Inducements, page 48* for further information.

Should the tank become empty during operations this will not lead to damage to the engine or the EATS system, as the remaining solution will circulate and cool the system. However, emissions from the engine will increase as the injection valve is closed and no exhaust aftertreatment will take place.

Engine Data	
Engine hours	101,1 h
Coolant temperature	80 C
Oil pressure	200 kPa
AdBlue/DEF	45 %✓
Engine Speed	600 Rpm

P0018827

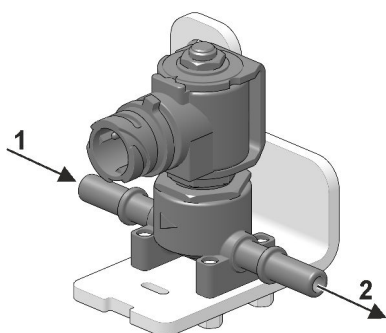

1. From engine
2. To tank

## Heating

Because AdBlue®/DEF freezes at around  $-11\text{ °C}$  ( $12.2\text{ °F}$ ) the tank is equipped with a heating coil that uses engine coolant. A solenoid valve controls the flow of coolant. The hoses between the tank and the pump are electrically heated and the hose connections are equipped with extra insulation.

There is a temperature sensor in the tank that transmits a signal to the control unit so that the pump cannot start until the AdBlue®/DEF is fluid. The standard system can handle thawing from  $-40\text{ °C}$  ( $-40\text{ °F}$ ). The system is emptied at shut down in order to prevent expansion damage due to freezing.

### **IMPORTANT:**

Hoses must be handled carefully and not twisted or bent excessively in order to avoid damaging the heating system.

## Storage

### **IMPORTANT:**

To prevent breakdown and evaporation during longterm storage, AdBlue®/DEF may not be stored at temperatures higher than  $25\text{ °C}$  ( $77\text{ °F}$ ) or in direct sunlight.

Remember that the solution expands upon freezing and to leave room for expansion in the tank when storing in spaces where there is a risk of freezing.

## Operation

### ⚠ WARNING!

In the case of any contact with eyes or skin the affected area must be thoroughly rinsed with lukewarm water. If you inhale any fumes, make sure you breathe fresh air.



P0011697

### ⚠ CAUTION!

Risk of corrosive damage. Contact with the fluid can cause irritation and corrosion.

Wear protective gloves!

Change gloves and clothing that have been in contact with the liquid.

### ⚠ CAUTION!

Risk of material damage.

AdBlue®/DEF oxidises metal and the capillary action creeps through lines at a speed of approx. 0.6 metres per hour.

If spillage occurs, electrical connectors must be replaced immediately. Do not try to clean with water or compressed air.

AdBlue®/DEF is not a combustible product. When exposed to high temperatures it will convert to ammonia and carbon dioxide. However, do not allow the solution to come into contact with other chemicals or be mixed with other chemicals.

When handling AdBlue®/DEF it is important that electrical connectors are connected or well-encapsulated. The solution is corrosive toward certain metals such as copper and aluminum. Should oxidation occur, it cannot be removed.

If connectors come into contact with the solution they must be replaced immediately to prevent the solution from seeping further along the copper wiring.

If the solution is spilled onto the engine, wipe it away and flush with water. White crystals of concentrated AdBlue®/DEF may form in the event of a spill; wash the crystals away using water.

### IMPORTANT:

AdBlue®/DEF spillages may not be washed into drains.

If a spill should occur, the solution must be absorbed using dry sand or other non-flammable material and handled according to local and national regulations.

## Cleaning tools and clothes

### ⚠ CAUTION!

Gloves must be changed. Take off contaminated clothes.

### ⚠ CAUTION!

Tools that come into contact with the fluid must be cleaned.

It is important that tools and clothes are thoroughly cleaned from AdBlue<sup>®</sup>/DEF so that the liquid or crystals are not transferred to other parts and cause them damaged.

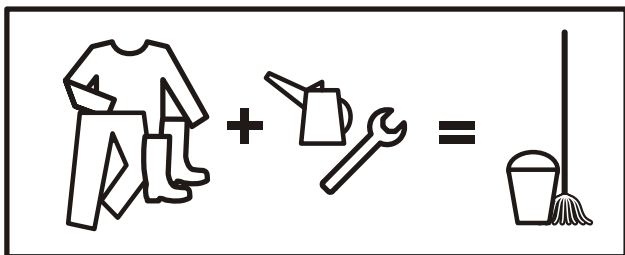

p0013225

### Contact with AdBlue<sup>®</sup>/DEF

- **skin contact** — flush with copious amounts of water and remove contaminated clothing.
- **eye contact** — flush thoroughly for several minutes; contact physician as necessary.
- **inhalation** — breathe fresh air and contact physician as necessary.

# Instruments and Controls

## DCU II (Display Control Unit)

The Volvo Penta DCU II instrument panel communicates with the engines control unit and has a number of functions as control, monitoring and diagnostics.

**NOTICE!** Settings and the type of engine data presented on the display may vary depending on the installation and engine model. Depending on the installation the DCU II can also be used as presentation display only.

**NOTICE!** The menus and illustrations shown here are the English version. Refer to the section *Settings* to change the display language.

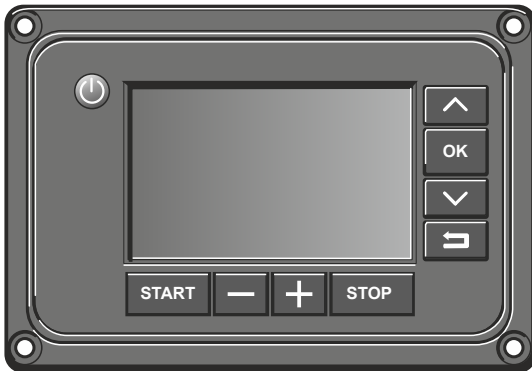

P0018811

 Turn On/Off the ignition

 **START** Start the engine

 Reduce engine rpm

 Increase engine rpm

 **STOP** Stop the engine

 Scroll upwards in menus

 **OK** Select and confirm in menus

 Scroll downwards in menus

 Return to previous menu selection



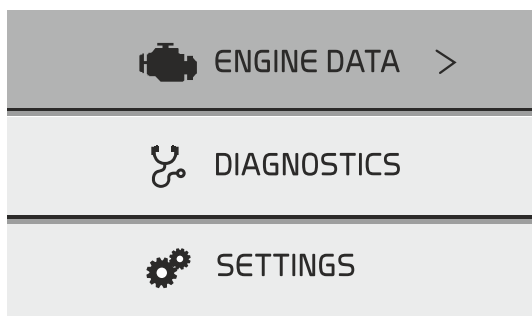



P0018295

## Display

The DCU II basic view shows three main menus.



- **ENGINE DATA** (ENGINE DATA), shows current engine data.
- **DIAGNOSTICS** (DIAGNOSTICS), shows active fault codes.
- **SETTINGS** (SETTINGS), shows display and engine settings.

Press  to proceed in the submenus and scroll using the panel arrow buttons.

Press  to return to previous menu.

## Status bar

The status bar with symbols for active malfunctions is shown in the top right of the display.

	Emission related malfunction
	EMS system malfunction

## Alarms and messages

Messages to the operator are of three types, color coded according to degree of severity.

When a message is shown on the display, press  to reach the diagnostic menu to get more information regarding registered faults and instructions for remedial actions.

- **ALARM** (ALARM), red text, the system has detected a serious fault — Volvo Penta recommends to immediately contact a qualified workshop .
- **WARNING** (WARNING), yellow text, the system has detected a fault — Volvo Penta recommends to contact a qualified workshop as soon as possible.
- **MEDDELANDE** (MESSAGE), blue text, non-critical engine message for the operator.

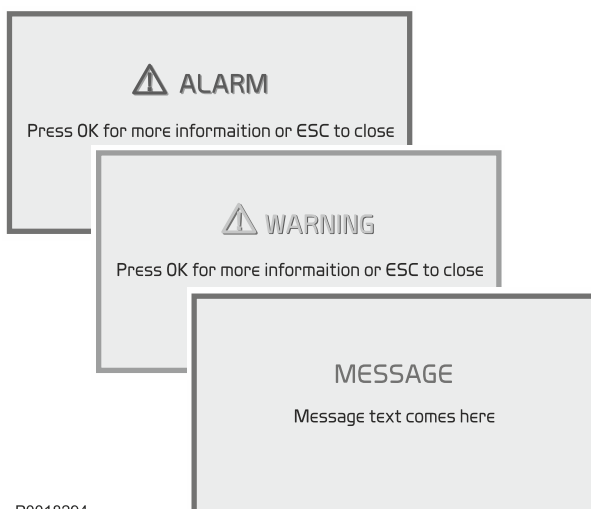

P0018294

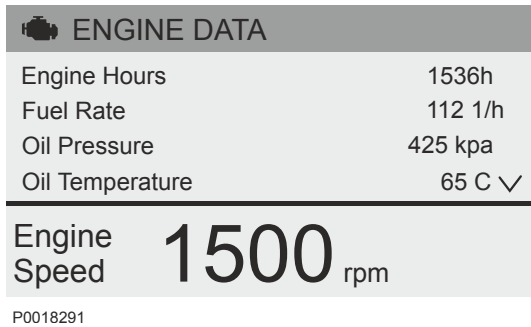

## Menus

### ENGINE DATA (ENGINE DATA)

Engine data shown may vary depending on the engine installation.

- **Engine Hours** (Engine Hour) (tim)
- **Engine Speed** (Engine Speed) (rpm)
- **Coolant Temperature** (Coolant Temperature) (°C)
- **Oil Pressure** (Oil Pressure) (kPa)
- **Fuel Rate** (Fuel Rate) (l/h)  
Current fuel consumption.
- **Boost Temperature** (Boost Temperature) (°C)
- **Boost Pressure** (Boost Pressure) (kPa)
- **Oil Temperature** (Oil Temperature) (°C)

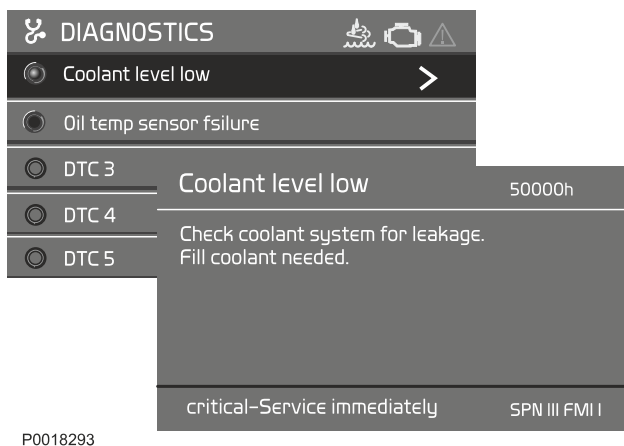

### DIAGNOSTICS (DIAGNOSTICS)

If the system detects a malfunction, the operator is informed via a pop-up message on the display. The fault codes are listed in the diagnostics menu; active fault codes are at the top of the list and are denoted by a green dot. For more information regarding cause and remedies, use the arrow button to scroll to the fault concerned and press **OK**. This will also provide information about number of engine hours when the fault became active and the SPN and FMI codes.

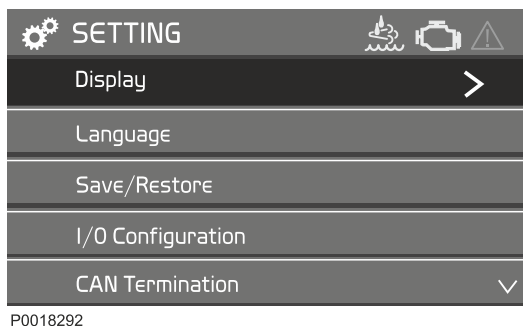

### SETTINGS (SETTINGS)

#### Display (Display)

- **Set backlight time** (Set backlight time). On/OFF, sets backlight to run in standby mode. *On* is the default setting.
- **Set backlight brightness** (Set backlight brightness). Adjust display backlight brightness using the panel arrow buttons.
- **Set Instrument Brightness** (Set Instrument Brightness). Sets backlighting in the display instrument.
- **Change background color** (Change background color). Select background color, gray or white.

#### Language (Language)

Sets the display language; chooses between English, French, German, Spanish and Chinese.

**Save/Restore (Save/Restore)**

- **Save current configuration** (Save current configuration). Save the current display settings.
- **Restore last configuration** (Restore last configuration). Restore the last displayed settings saved.
- **Restore default configuration** (Restore default configuration). Restores *all* display setting menus to factory settings.

**NOTICE!** The settings in the following menus do not normally need to be changed; should a change be necessary it must be carried out by an authorized Volvo Penta technician. Refer to the installation manual for further engine information.

**Authorized Volvo Penta dealer or OEM only**

- I/O Status (I/O Status)
- CAN Termination (CAN Termination)
- Stop Logic DCU (Stop Logic DCU)
- Potentiometer supply (Potentiometer supply)
- Speed Control (Speed Control)
- Control display unit (Control display unit)
- Genset/VE (Genset/VE)
- Buzzer (Buzzer)
- Information (Information)

# Starting

Make it a habit of giving the engine and engine room a visual check before starting. This will help you to discover quickly if anything abnormal has happened, or is about to happen. Also check that instruments and warning displays show normal values after you have started the engine.

## **⚠ WARNING!**

Never use start spray or similar agents to start an engine. This may cause an explosion in the inlet manifold. Risk of personal injury.

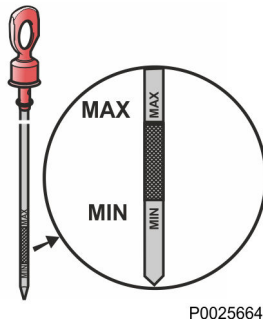

## Before Starting

- Check that the oil level is between the MIN and MAX marks. Refer to *Oil level, checking and topping up*.
- Check the fuel pre-filter; refer to *Draining condensate, fuel system, page 61*.
- Check that no leakage of oil, fuel or coolant is present.
- Check the coolant level and that the radiator is not blocked externally. Refer to *Coolant Level, Checking and Topping Up, page 67* and *Charge Air Cooler, External Cleaning, page 68*.

## **⚠ WARNING!**

Do not open the coolant filler cap when the engine is hot, except in emergencies as this could cause serious personal injury. Steam or hot fluid could spray out.

- Turn the main switch on.

## **IMPORTANT:**

- Never break the circuit with the main switch while the engine is running. Alternator and electronics could be damaged.
- Move the engine speed control to idle, and open the disengageable clutch/gearbox if installed.

## Starting the Engine

The pre-heating time is adjusted to suit the engine temperature, and can last for up to 50 seconds both before and after starting.

The starter motor connection time is maximized to 20 seconds. After that, the starter motor circuit is temporarily cut to protect the starter motor against overheating.

## DCU II (Display Control Unit)

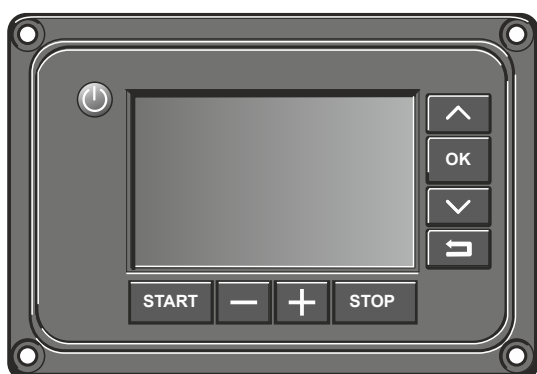

P0018811

- 1 Press the  button to switch on the ignition. The display switches on at the same time.
- 2 Press the START button to start the engine.

## Starting in Extreme Cold

Certain preparations must be made to enable engine starting in extreme cold, and in some cases to make starting possible at all:

- Use a winter grade fuel (of a well-known make) that is approved for the prevailing temperature. This reduces the risk of paraffin wax precipitation in the fuel system. At extremely low temperatures, we recommend the use of a fuel heater.
- Use a synthetic engine oil of a viscosity recommended for the prevailing temperature to achieve satisfactory lubrication. Refer to *Viscosity, page 83*. Synthetic lubricants are able to handle a wider temperature range than mineral-based lubricants.
- Pre-heat the coolant with a separately-installed electric engine heater. In extreme cases, a diesel-fired engine heater may be necessary. Ask your Volvo Penta dealer for advice.
- Make sure the cooling system is filled with a coolant mixture. Refer to *Maintenance, page 66*.
- The batteries must be in good condition. Cold weather reduces battery capacity. Increased battery capacity may be necessary.

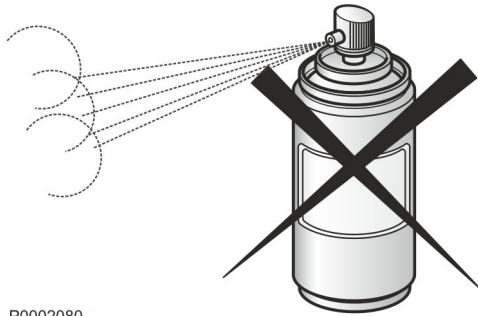

P0002080

## Never Use Start Spray

### **⚠ WARNING!**

Never use start spray or similar agents to start an engine. This may cause an explosion in the inlet manifold. Risk of personal injury.

## Starting Using Auxiliary Batteries

### **⚠ WARNING!**

Explosion hazard. Batteries contain and give off an explosive gas which is highly flammable and explosive. A short circuit, open flame or spark could cause a violent explosion. Ventilate well.

- 1 Check that the auxiliary batteries are connected (series or parallel) so that the rated voltage corresponds to the engine system voltage.
- 2 First connect the red (+) jumper cable to the auxiliary battery, then to the flat battery. Then connect the black (-) jumper cable to the auxiliary battery and to a location that is **somewhere away from the discharged battery**, e.g. the main switch negative terminal or the negative terminal on the starter motor.
- 3 Start the engine.

### **⚠ WARNING!**

Do not touch the connections during the start attempt: Risk of arcing.  
Do not bend over any of the batteries either.

- 4 Remove the cables in the reverse order.

### **IMPORTANT:**

The ordinary cables to the standard batteries must not under any circumstances be loosened.

# Operation

Correct operating technique is very important for both fuel economy, environmental protection and engine life. Always let the engine warm up to normal operating temperature before operating at full power. Avoid sudden throttle openings and operation at high engine speed.

## Reading the Instruments

Check all instruments directly after starting, and then regularly during operation.

**NOTICE!** On engines in continuous operation, it is recommended that the lubrication oil level is checked at least every 24 hours. Refer to *Oil level, checking and topping up*.

## Alarms

If the EMS receives abnormal signals from the engine, the control unit generates fault codes and alarms, in the form of lamps and audible warnings. This is done by means of CAN signals to the instrument.

More information about fault codes and fault tracing can be found in the chapter *Fault handling*.

## Maneuvering

### Operation at low load

Avoid long-term operation at idle or at low load. It takes a long time for the engine to reach working temperature, resulting in high viscosity of the oil and large clearances in the engine mechanics. In cold climate, it takes even longer.

The combustion temperature and cylinder pressure can become so low that an effective combustion cannot be ensured. At these conditions unburned fuel could dilute the lubricant oil. Because of the low cylinder pressure, the piston ring performance could be affected causing oil from the crankcase to pass the rings and go further out with the exhaust gases. This mixture of unburned fuel and oil in exhaust gases is referred to as "slobber". A new engine produces more "slobber" at low load compared to an engine with more hours of operation.

At low load, the pressure in the turbocharger is low and oil could seep past the turbocharger seals and mix with the air into the engine. The consequences can be carbon build-up on valves, piston crowns and the exhaust turbine, which could affect engine performance.

Both conditions can lead to increased oil consumption and eventually external oil leakage from joints in the exhaust system. For example, leakage could be seen at the exhaust manifold, before and after the turbo, around the muffler and in worse case even in the exhaust end pipe. Consequences could lead to clogged exhaust gas recirculation systems and exhaust aftertreatment systems.

Signs of oil leaking caused by "slobber" do not indicate an engine problem but indicates low load operation. To minimize the risk of malfunctions caused by operation at low load, follow these points as a complement to normal maintenance:

- Run in the engine as soon as possible.
- Load the engine so it reaches working temperature as soon as possible.
- Turn off the engine instead of running on idle for longer periods.
- Avoid load levels below 20% as constant operation.
- If the engine is regularly tested without load, limit the duration of the operation to 5 minutes. Run the engine at full load for about 4 hours once a year, for



the carbon deposits in the engine and exhaust system to burn off.

- If visible slobber has occurred, it can be burned off by running the engine on at least 30% load for about 40-60 minutes.

# Engine Shutdown

During longer breaks in operation, the engine must be warmed up at least once every two weeks. This prevents corrosion in the engine. If you expect the engine to remain unused for two months or more, it must be preserved: Refer to the chapter *Storage*, page 80.

## Before Engine Shutdown

Let the engine run at high idle (1500 or 1800rpm) for a minimum of 5 minutes before the shutdown after normal use. Normal use is defined as minimum 50% load. After use with less than 50% load, high idle for approximately 3 minutes is sufficient. This allows engine temperature equalization and prevents boiling once stopped and also allows the turbochargers to cool down. This contributes to long, fault-free service life.

**NOTICE!** Do not turn off the main switch within 30 seconds after turning off the ignition. This is in order to save engine data to the engine control unit.

## Stop the Engine

### **CAUTION!**

The EATS system needs time to for automatically drainage and depressurizing.

Wait at least two minutes after the engine been turned off before removing the AdBlue/DEF hoses.

- 1 Disengage the clutch, if possible.
- 2 Press the STOP button to turn off the engine.
- 3 Press the  button to turn off the ignition.

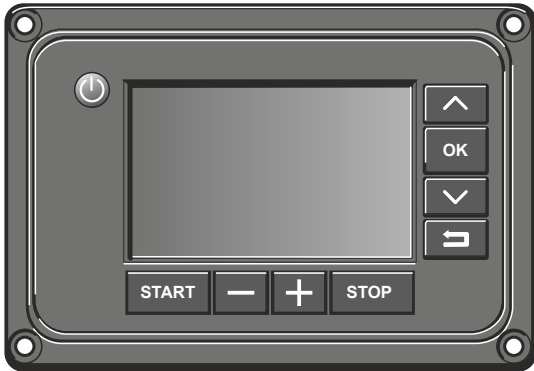

P0018811



P0025697

## Auxiliary Stop

For location of the extra stop, refer to *Maintenance, page 54*.

### **⚠ WARNING!**

Working with or approaching a running engine is a safety risk. Watch out for rotating components and hot surfaces.

## After Engine Shutdown

- 1 Check the engine and engine compartment for leaks.
- 2 Turn off the main switches before any long stoppage.
- 3 Carry out maintenance in accordance with the schedule.

### **For longer breaks in operation**

During longer breaks in operation, it is recommended that the engine is warmed up at least once every two weeks. This prevents corrosion in the engine.

If you expect the engine to be unused for two months or more, it should be conserved. Refer to *Storage, page 80*.

### **IMPORTANT:**

If there is a risk of freezing, the coolant in the cooling system must have adequate antifreeze protection.

Refer to *Maintenance, page 66*.

### **IMPORTANT:**

A poorly charged battery can freeze and burst.

Refer to *Battery, Charging*.

# Fault handling

## Diagnostic Function

The purpose of the diagnostic function is to monitor, control and protect the engine and its surrounding system and components from damage, as well as to ensure a minimal environmental impact.

If a malfunction is detected the diagnostic function informs of the occurred fault in the form of a fault code. The fault code provides guidance when fault tracing. All fault codes and fault messages can be found in the *Fault Code Register*.

The operator is warned that there is a malfunction via the instruments. Depending on the instrumentation in use, the fault message is shown in various ways. Fault codes can also be read out by the Volvo Penta diagnostic tool.

Depending on the severity of the fault, the diagnostic function will take various actions to protect the engine and limit emissions (e.g. torque derate, idle speed only, engine shut down etc. )

## DCU II (Display Control Unit)

### DIAGNOSTICS

If the system detects a malfunction the driver/operator is informed via a pop-up message on the display. The fault codes are listed in the diagnostics menu; active fault codes are at the top of the list and are denoted by a green dot. For more detailed information regarding the cause and remedies, use the arrow buttons to scroll to the fault concerned and press **OK**. This will also provide information about the number of engine hours when the fault became active and the SPN and FMI codes.

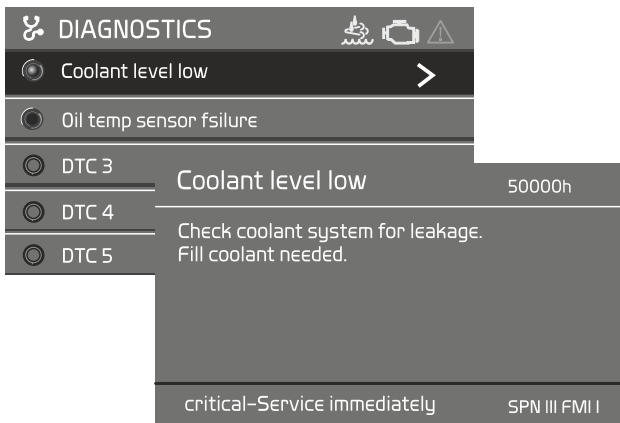

## Erasing fault codes

The memory of the diagnostic function is reset when the power to the engine is disconnected. When the power is switched on again, the diagnostic function will check if there are any malfunctions in the system. If so a new fault codes is registered.

If a malfunction has not been corrected it will be registered once again and has to be acknowledged again. The Volvo Penta diagnostic tool VODIA must be used to erase a fault code.

## Fault Tracing

A number of symptoms and possible causes of engine malfunctions are described in the table below. Always contact your Volvo Penta dealer if any problems occur which you cannot solve by yourself.

**NOTICE!** Read through the safety advice for care and maintenance work in the chapter *Safety precautions for maintenance and service operations* before you start work.

### Symptoms and possible causes

The diagnosis button lamp flashes	Please refer to <i>Alarm handling</i>
Engine cannot be stopped	2, 5
Starter motor does not rotate	1, 2, 3, 4, 5, 6, 7, 23
Starter motor rotates slowly	1, 2
Starter motor rotates normally but the engine does not start	8, 9, 10, 11,
Engine starts but stops again	8, 9, 10, 11, 12
Engine does not reach correct operating speed at full throttle	9, 10, 11, 12, 20, 23, 24
Engine runs roughly	10, 11
High fuel consumption	12, 14, 23
Black exhaust smoke	12
Blue or white exhaust smoke	14, 21
Too low lubrication oil pressure	15
Excessive coolant temperature	16, 17, 18, 19
Too low coolant temperature	19
No, or poor charge	2, 22





- 1 Discharged batteries
- 2 Poor contact/open circuit in electrical wiring
- 3 Main switch turned of
- 4 Main fuse faulty
- 5 Faulty ignition lock
- 6 Faulty main relay
- 7 Faulty starter motor-/solenoid
- 8 No fuel:
  - fuel cocks closed
  - fuel tank empty/wrong tank connected
- 9 Blocked fuel fine-filter/pre-filter (due to contaminations, or stratification in the fuel at low temperature)
- 10 Air in the fuel system
- 11 Water/contamination in fuel
- 12 Insufficient air supply to the engine:
  - blocked air filter
  - air leakage between the turbo and the engine intake manifold
  - dirty compressor part in the turbocharger
  - faulty turbo compressor
  - poor engine compartment ventilation
- 13 Coolant temperature too high
- 14 Coolant temperature too low
- 15 Oil level too low
- 16 Coolant level too low
- 17 Air in coolant system
- 18 Faulty circulating pump
- 19 Defective thermostat
- 20 Blocked charge air cooler
- 21 Oil level too high
- 22 Alternator drive belt slips
- 23 High back pressure in the exhaust system
- 24 Break in "Pot+" cable to throttle

## EATS Warnings and Inducements

EATS system monitoring checks the quality of the AdBlue®/DEF, the level in the tank and the correct function of the system components. If a fault is detected, the operator is warned via the instrument panel and the engine speed and torque is limited. To enable fault tracing and the remedy of any faults, the engine can be re-started according to a start schedule; refer to *EATS Inducements*, page 48.

**NOTICE!** Warning messages and symbols may vary depending on the installation; shown here are those seen on panels sold by Volvo Penta.

### Warning Symbols

<p>Stimulus for power reduction warning. A fault has been detected in the EATS system. or The AdBlue®/DEF tank level has dropped to the first warning level.</p>	
  	<ul style="list-style-type: none"> <li>• The warning symbol shines with a constant yellow light.</li> <li>• The EATS symbol shines with a constant light.</li> </ul>
<p>Major stimulus for power reduction warning. or The AdBlue®/DEF tank level has dropped to the second warning level.</p>	
  	<ul style="list-style-type: none"> <li>• The warning symbol shines with a constant red light.</li> <li>• The EATS symbol flashes.</li> </ul>



## Quality shortcomings and component defects

If the system signals a quality shortcoming or component defect, check the following:

- that the level sensor in the AdBlue<sup>®</sup>/DEF tank is connected.
- that system hoses and the injection valve are not clogged or disconnected.
- that the injection valve is connected.
- that the AdBlue<sup>®</sup>/DEF pump is connected.
- that the SCR system electrical cables are connected.
- that the NO<sub>x</sub> sensors are connected.
- that the exhaust temperature sensor is connected.
- that the temperature sensor for the AdBlue<sup>®</sup>/DEF is connected.
- that there are no leaks in the exhaust system where substantial amount of solution can escape.
- that the EGR valve is not stuck.

If the fault can not be remedied with any of the above, refer to *EATS Inducements*, page 48.

## EATS Inducements

### Low tank level

- 1 When the level in the DEF tank falls to 15%, a warning lamp lights up.
- 2 When the tank level has dropped to around 6% the warning lamp will flash. Engine torque will drop to 75%. Ramp-down takes around 1 minute.
- 3 The engine will drop to idle with a 50% torque reduction 7 minutes after the tank level reaches 6%. Ramp-down takes around 3 minutes.
- 4 If the engine is started when the tank level falls below 6%, the engine will only run at idle.
- 5 For the engine to revert to full power the tank level must be above 12%. The tank level must be above 21% for the system to extinguish the warning lamp and cancel the fault message.

### AdBlue/DEF high temperature, quality and component faults

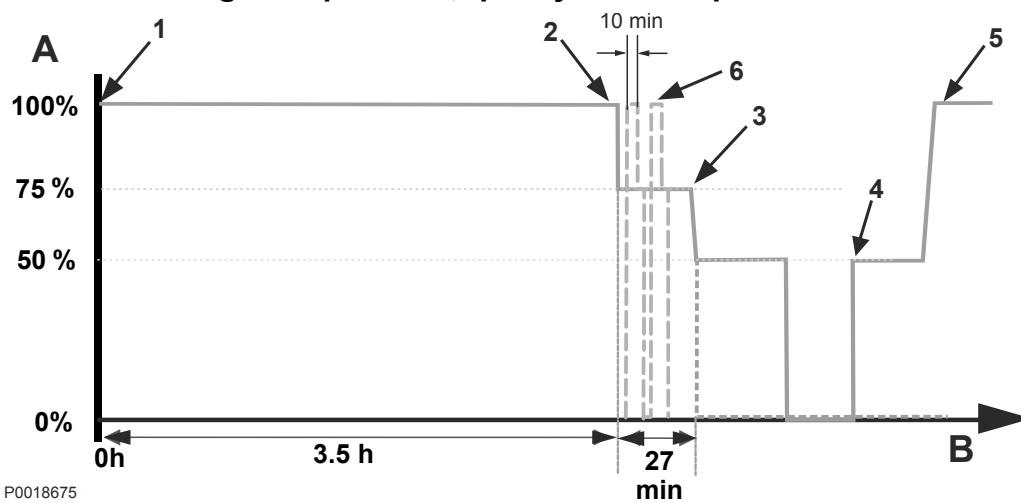

P0018675

- A Engine rpm and torque
- B Time axis

- 1 A fault is detected and the warning lamp lights up.
- 2 If the fault is not remedied after 3.5 hours engine torque will drop to 75%. Ramp-down takes around 1 minute. The warning lamp flashes.
- 3 After 27 minutes the engine will drop to idle with a 50% torque reduction. Ramp-down takes around 3 minutes.
- 4 Following re-start, the engine will run at idle with a 50% torque reduction. DEF quality problems will require service tools to reset the system.
- 5 When component faults are remedied the engine will revert to full power.
- 6 Depending on the installation, it is possible after the first 3.5 hours, but before 4 hours, to manually override the system actions and run the engine at full power for 2 x 10 minutes. After 10 minutes the engine drops to 75% power. Each 10-minute period requires a manual activation.
- 7 If an additional fault recurs within 40 hours after the first fault was remedied, available running time will be reduced to 30 minutes from the moment the fault is detected.

# Fault Code Register

This chapter lists the fault codes that may occur. In cases where the operator himself is able to remedy faults easily we refer to the section concerned. In the case of other faults or where a fault remains, contact a Volvo Penta workshop.

## Fault codes

SPN	FMI	Component
20	1, 3, 4, 5, 18	Engine Coolant Pressure Sensor
51	3, 5, 7, 12, 13	Engine Throttle position
91	0, 9, 19	Accelerator Pedal position
94	3, 5, 12, 18	Fuel Delivery Pressure <i>Maintenance, page 61</i>
97	0, 4	Water In Fuel Indicator <i>Draining condensate, fuel system, page 61</i>
98	1, 4, 5, 18	Engine Oil Level <i>Oil level, checking and topping up, page 59</i>
99	0	Engine Oil Filter Differential Pressure
100	1, 3, 4, 5, 18	Engine Oil Pressure <i>Oil level, checking and topping up, page 59</i>
101	0, 3, 5	Crankcase Pressure
102	0, 3, 4, 5, 16	Boost Pressure
105	0, 4, 5, 16	Boost Temperature
107	0, 3, 4, 5, 12	Air Filter Differential Pressure
108	5	Ambient Air Pressure
110	0, 4, 5, 16	Engine coolant temperature <i>Coolant Level, Checking and Topping Up, page 67</i>
111	1, 3, 4, 5, 18	Engine Coolant Level <i>Coolant Level, Checking and Topping Up, page 67</i>
131	3, 5, 12	Engine Exhaust Back Pressure
158	0, 1, 2	System Voltage <i>Battery, Charging</i>
172	4, 5	Ambient Air Temperature Sensor
173	0, 16	Exhaust Gas Temperature
175	0, 3, 4, 5, 16	Engine Oil Temperature <i>Oil level, checking and topping up, page 59</i>
190	0, 16	Engine Speed
626	3, 4, 5	Preheat Relay
628	2, 14	Program Memory
636	7, 8, 9	CAM Speed sensor
637	2, 8, 9	Crank Speed sensor
639	2	J1939 Network #1 Primary Vehicle Network
647	3, 4, 5	Engine Fan Driver
651	3, 5	Fuel Injector, Cylinder #1
652	3, 5	Fuel Injector, Cylinder #2
653	3, 5	Fuel Injector, Cylinder #3
654	3, 5	Fuel Injector, Cylinder #4
655	3, 5	Fuel Injector, Cylinder #5
656	3, 5	Fuel Injector, Cylinder #6

SPN	FMI	Component
677	3, 4, 5, 6	Starter motor relay
729	5, 6, 7, 12	Engine Inlet Air Heater Driver
970	3, 4, 5, 11, 14	Engine Stop Switch
1136	16	Engine ECM Temperature
1188	3, 4, 5	Wastegate Valve Driver
1485	7	ECM Main Relay
1639	3	Fan Speed
1668	2	J1939 Network #4 (engine subnet)
1761	3, 5, 12, 17, 18	Aftertreatment Reagent Tank Level
2000	9	Lost Communication with EECU
2017	9	Lost Communication (Source Address 17)
2036	9	Lost Communication (Source Address 36)
2659	18	Engine Exhaust Gas Recirculation (EGR) Mass Flow Rate
2791	7	EGR Valve Control
3031	0, 4, 5, 12	Aftertreatment Reagent Tank Temperature
3216	2, 3, 5, 9, 11, 12, 13, 14	NOx Sensor Inlet
3226	2, 3, 5, 7, 9, 12, 13, 14	NOx Sensor Outlet
3241	5, 4, 12, 19	Exhaust Gas Temperature
3360	9	Aftertreatment Fluid Controller
3361	12	Aftertreatment Reagent Dosing Unit
3363	3, 4, 5	Aftertreatment Tank Heater
3364	2, 12, 17, 18	Aftertreatment Tank Reagent Quality
3464	3, 4, 5, 7, 10, 12	Engine Throttle Actuator
3509	3, 4	Sensor Supply Voltage #1 (+5 V DC)
3510	3, 4	Sensor Supply Voltage #2 (+5V DC)
3511	3, 4	Sensor Supply Voltage #3 (+5V DC)
3519	3, 4, 5	Aftertreatment Reagent Tank Temperature
3520	4, 5, 12	Aftertreatment Reagent Quality
3521	14	Aftertreatment Reagent Quality
3532	4, 5, 12	Aftertreatment Reagent Tank Level
3597	3, 4	ACM Supply Voltage
3598	3, 4	ACM Supply Voltage
4334	4, 5	Aftertreatment Reagent Pressure
4354	3, 4, 5	Aftertreatment Reagent Hose Heater 1
4355	3, 4, 5	Aftertreatment Reagent Hose Heater 2
4356	3, 4, 5	Aftertreatment Reagent Hose Heater 3
4364	1	Aftertreatment system performance
4366	14	Aftertreatment Reagent System
4374	0, 1	Aftertreatment Reagent Pump Motor Speed
4375	0, 1, 3, 4, 5, 12, 14	Aftertreatment Reagent Pump Control
4376	3, 4, 5, 7	Aftertreatment Reagent Direction Valve
5016	4	ACM Actuator Supply Voltage #4
5392	31	Aftertreatment Reagent Pump Control

<b>SPN</b>	<b>FMI</b>	<b>Component</b>
5394	3, 5, 12, 14	Aftertreatment Reagent Dosage Valve
5435	14	Aftertreatment Reagent System
5485	14	Aftertreatment Reagent Pump
520335	5	ECM Battery Potential
520416	9	Lost communication with reductant control module on engine subnet
520567	0, 3, 4, 5, 16	Aftertreatment Exhaust Temperature - Wet
520570	3, 4, 5, 11	Engine Oil Pressure Before Filter
520688	0, 3, 4, 5, 16	Aftertreatment Exhaust Temperature - Dry
520689	3, 4, 5	EGR "A" / Volvo Compression Brake (VCB) Control Circuit
520690	3, 5	EGR "A" Control / Turbocharger/Supercharger Wastegate Solenoid "A"
520691	14	Torque Speed Control 1 Received With Errors (Counter or Checksum)

# Maintenance Schedule

Your Volvo Penta engine and its equipment are designed for high reliability and long life. The engines are built to have the smallest possible environmental impact. If given preventive maintenance, according to the maintenance schedule, these qualities will be retained and unnecessary malfunctions will be avoided. In order for the warranty to be valid, the owner must make sure that the services in the service intervals are performed.

**NOTICE!** For emission related warranty rights see Emission Control System Warranty Statement.

## Service Intervals

Service intervals are shown below. The service content can be found in the Service Protocol available for download at [www.volvopenta.com](http://www.volvopenta.com).

**NOTICE!** More information on how to perform service and maintenance can be found in the Service and Maintenance handbook. Information on how to purchase the Service and Maintenance handbook can be found at [www.volvopenta.com](http://www.volvopenta.com).

## Extended service intervals

The interval between engine oil changes may be extended in certain circumstances. To determine whether the service interval may be extended, Volvo Penta's conditions for extended service intervals must be met and an oil analysis performed. Contact your Volvo Penta dealer for further information.

Where both operational and calendar times are specified, perform the maintenance item at whichever time is the sooner.

Special Interval Service **S1** Every 1000 hours of operation, or every 12 months.<sup>(1)(2)</sup>

Special Interval Service **S2** Oil analysis\*

Special Interval Service **S3** After the first 1000 hours of operation.  
Valve clearance

Type **A** Service Every 1000 hours of operation.

Type **B** Service Every 2000 hours of operation.

Type **C** Service Every 8000 hours of operation.

1) Oil change intervals vary, depending on oil grade and sulfur content of the fuel. Refer to *Technical Data*, page 83.

2) Change oil filters every time the oil is changed.

# Maintenance

This chapter describes the most common maintenance items. Refer to *Maintenance Schedule, page 52* for service intervals.

**NOTICE!** More information on how to perform service and maintenance can be found in the Service and Maintenance handbook. Information on how to purchase the Service and Maintenance handbook can be found at [www.volvopenta.com](http://www.volvopenta.com).

## CAUTION!

Read through the safety advice before starting any work.

## WARNING!

Care and maintenance work should be done with the engine stopped unless otherwise specified. Stop the engine before opening or removing the engine hatch/hood. Make it impossible to start the engine by removing the start key and cutting the system voltage with the main switches.

When ordering service or spare parts, always specify the engine and transmission identification number. Refer to *Technical Data, page 88*.

## Orientation

- 1 Starter motor
- 2 Turbo
- 3 Oil filter
- 4 Fuses
- 5 Auxiliary Stop
- 6 Alternator
- 7 Oil filler cap, engine
- 8 Oil dipstick
- 9 Fuel Filter
- 10 Fuel pre-filter with water separator
- 11 Control Unit, EMS

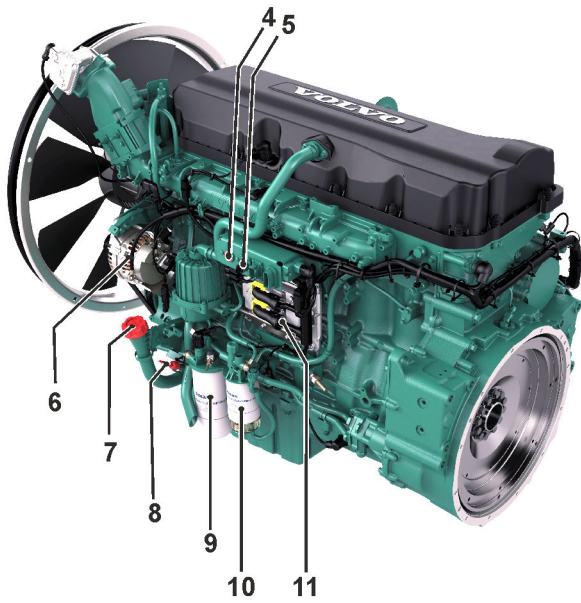
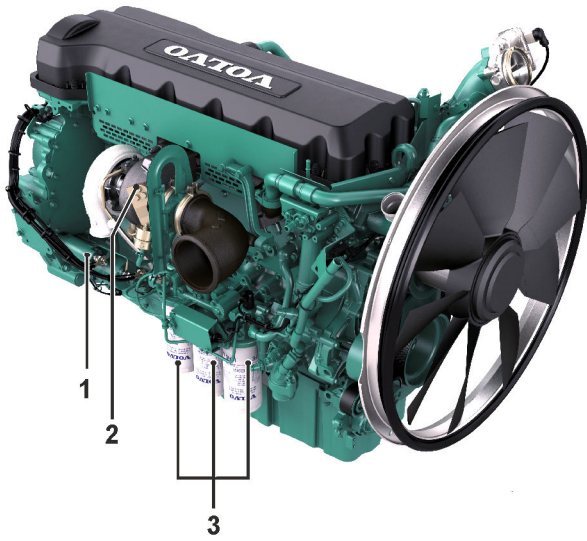



## Engine, General

### General inspection

Make it a habit to give the engine and engine compartment a visual inspection before starting the engine and after operation once the engine has stopped. This will help you to discover quickly if anything abnormal has happened, or is about to happen.

Look especially carefully at oil, fuel and coolant leakage, loose bolts, worn or poorly tensioned drive belts, loose connections, damaged hoses and electrical cables. This inspection only takes a few minutes and can prevent serious malfunctions and expensive repairs.

#### **▲ WARNING!**

Risk of fire.

Remove all accumulations of fuel, oil and grease when detected on the engine or in the engine room.

#### **▲ WARNING!**

If an oil, fuel or coolant leak is detected, the cause must be investigated and the fault rectified before the engine is started.

#### **IMPORTANT:**

Washing with a power washer: Never aim the water jet at radiators, charge air cooler, seals, rubber hoses or electrical components.

### Air Filter, Check and Replace

The engine is equipped with electronic air filter indication.

The control unit provides an output signal which is announced as a warning on the instrument panel. The warning indicates a pressure drop in the air filter, which must then be checked and possibly changed.

- Scrap the old filter. No cleaning or re-use is permissible
- In continuous operation, the filter should be checked every 8 hours. For operations in extremely dirty environments such as coal mines and rock crushing mills, special air filters must be used.

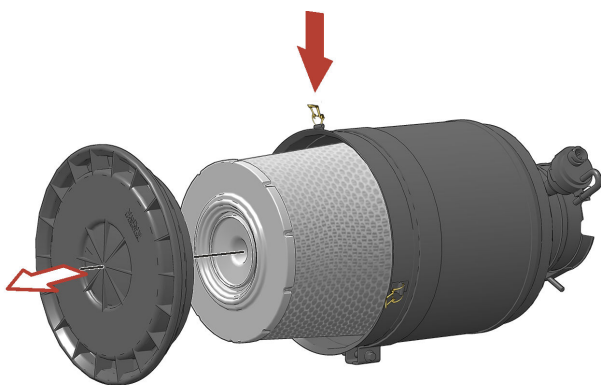

P0018636

## Charge Air Pipe, Leakage Check

Inspect the condition of the charge air hoses, hose unions and clamps for cracks and other damage. Change as necessary.

Clamps must be tightened using a torque wrench to  $9 \pm 2 \text{ Nm}$  ( $6.6 \pm 1.5 \text{ lbf.ft.}$ ).

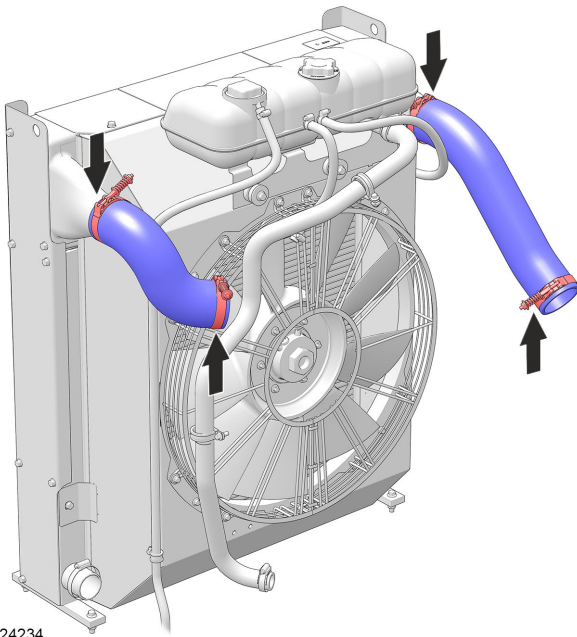

P0024234

## Drive Belt and Alternator Belt, Inspection

### **▲ WARNING!**

Working with or approaching a running engine is a safety risk. Watch out for rotating components and hot surfaces.

### **IMPORTANT:**

Always change a belt which looks worn or cracked.

Inspections must be carried out after operations, while the belts are hot.

You should be able to depress the alternator belt and the drive belt about 3-4 mm between the pulleys.

The alternator belts and drive belts have automatic belt tensioners and do not need to be adjusted.

Check the condition of the drive belts. Replace as necessary; refer to *Alternator Belt, Replace*, page 58 and *Drive belt, change*, page 57.

## Drive belt, change

### IMPORTANT:

Always change a belt which looks worn or cracked.

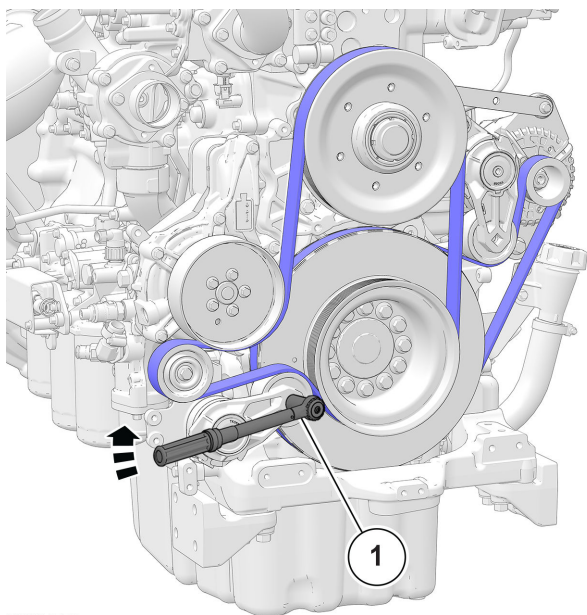

P0024571

- 1 Disconnect the main switch(es) and check that the engine is not connected to system voltage.
- 2 Remove the fan guard and fan ring round the cooling fan.
- 3 Remove the belt guard.
- 4 Place a 1/2" square wrench in the belt tensioner (1). Lift the wrench and remove the drive belt.
- 5 Thread the drive belt round the fan and remove it.
- 6 Check that the pulleys are clean and undamaged.
- 7 Thread the new drive belt over the fan.
- 8 Lift the 1/2" wrench and install the new drive belt.
- 9 Install the belt guards.
- 10 Install the fan guard and fan ring round the cooling fan.
- 11 Start the engine and perform a function check.

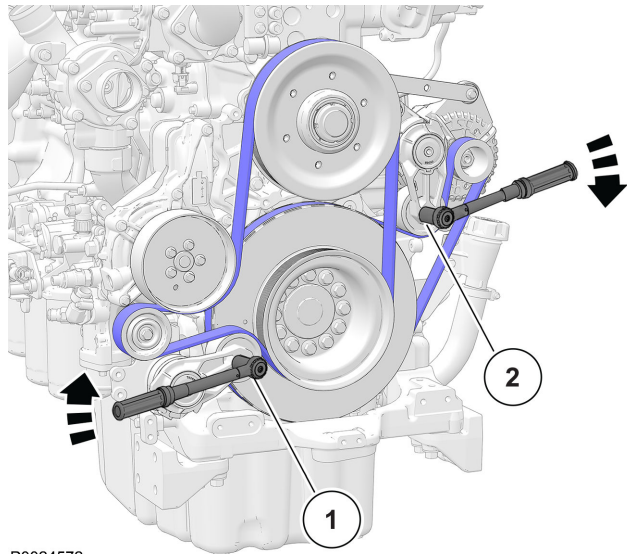

P0024572

## Alternator Belt, Replace

### IMPORTANT:

Always change a belt that is oily, worn or damaged.

- 1 Disconnect the main switch(es) and check that the engine is not connected to system voltage.
- 2 Remove the fan guard and fan ring round the cooling fan.
- 3 Remove the belt guard.
- 4 Place a 1/2" square wrench in the belt tensioner (1). Lift the wrench up and lift the water pump drive belt off.
- 5 Place a 1/2" square wrench in the belt tensioner (2). Press the wrench down and remove the alternator belt.
- 6 Check that the pulleys are clean and undamaged.
- 7 Press the 1/2" wrench in the belt tensioner (2) down and install the new alternator drive belt.
- 8 Lift the 1/2" wrench in the belt tensioner (1) and re-install the water pump drive belt.
- 9 Install the belt guards.
- 10 Install the fan guard and fan ring round the cooling fan.
- 11 Start the engine and perform a function check.

## Lubrication System

Oil change intervals may vary according to the lubrication oil grade, fuel sulfur content and running conditions. Refer to *Technical Data*, page 83.

The oil change interval may under certain conditions be increased. To see if the engine complies Volvo Penta oil analysis needs to be performed. Contact your Volvo Penta dealer for further information.

**NOTICE!** Oil change intervals must never exceed a period of 12 months.



P0002089

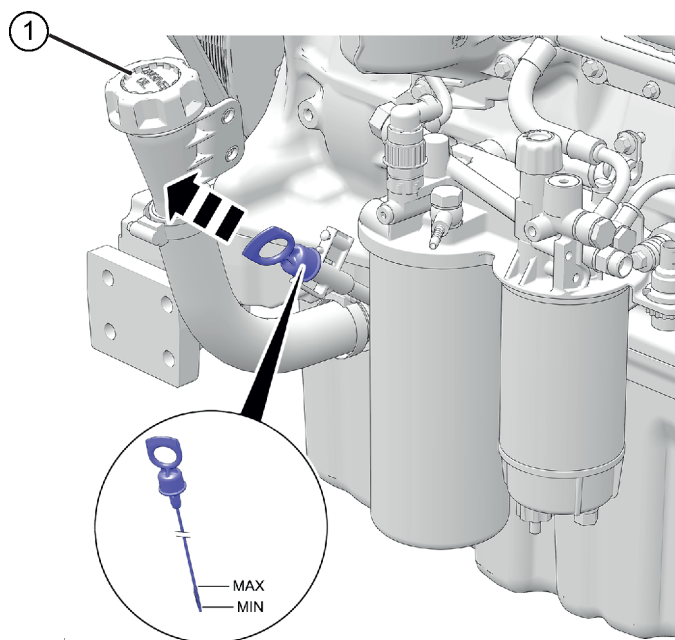

P0025622

## Oil level, checking and topping up

The oil level must be inside the marked area on the dipstick and must be checked daily before the first start.

- Top up with oil via the filler opening (1). Check that the correct level has been achieved. If the engine is stationary, wait for a few minutes to allow the oil to run down into the oil pan.
- Do not fill above the maximum oil level. Only use a recommended grade of oil; refer to *Technical Data*, page 83.
- The oil level is only measured at the time the ignition is turned on, not continually during operation.

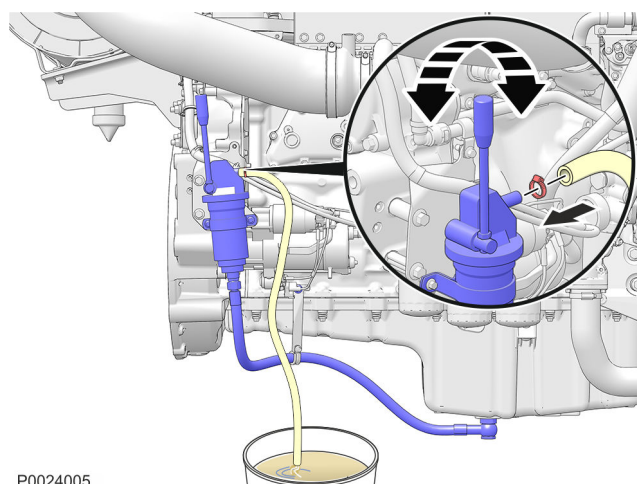

P0024005

## Engine Oil, Change

### **▲ WARNING!**

Hot oil and hot surfaces can cause burns.

Oil changes must be done when the engine is hot.

- 1 Connect the drain hose to the oil drain pump and check that no leakage can occur.
- 2 Pump the oil out (or remove the bottom drain plug and drain the oil). Collect all the old oil and old filters, and hand them to a re-cycling station for destruction.
- 3 Remove the drain hose (or install the bottom drain plug).
- 4 Fill with engine oil.  
For change volume, please refer to *Technical Data*, page 83.

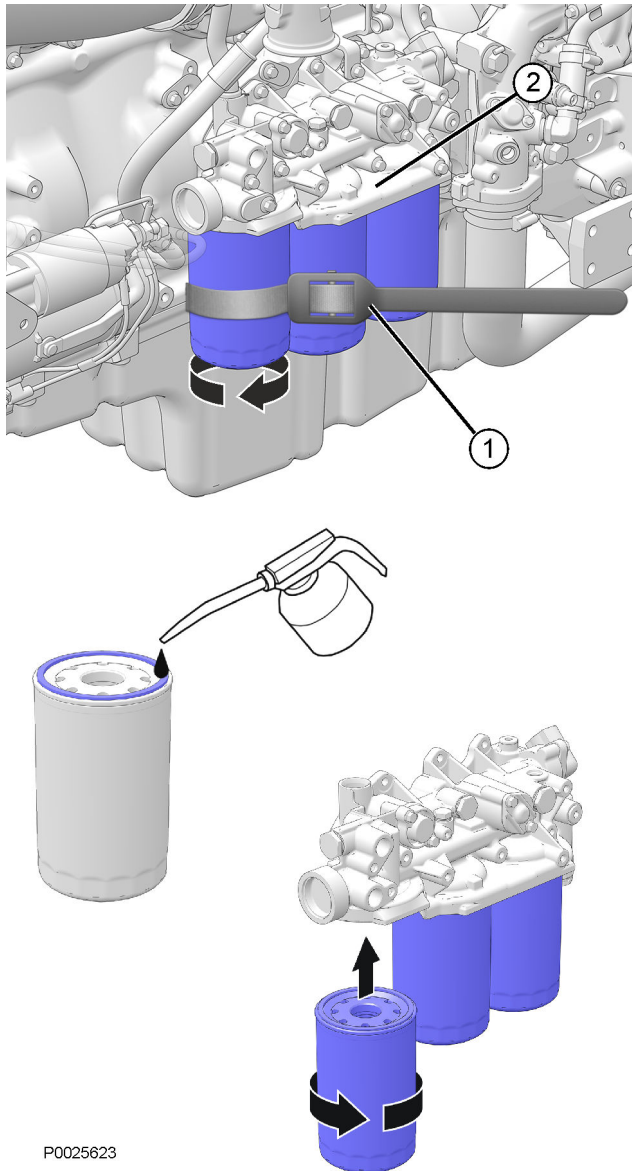

P0025623

## Oil Filter/By-pass Filter, Change

### **⚠ WARNING!**

Hot oil and hot surfaces can cause burns.

- 1 Clean the oil filter bracket (2).
- 2 Remove all oil filters with a suitable oil filter extractor (1).
- 3 Clean the mating surface of the oil filter bracket. Make sure that no remnants of old oil seal are left behind. Carefully clean round the inside of the protective rim (2) on the oil filter bracket.
- 4 Put a thin layer of engine oil on the seal rings of the new oil filters.
- 5 Install the new oil filters. Tighten the two full-flow filters (on the right of the illustration) 1/2–3/4 of a turn after they bottom. Tighten the bypass filter 3/4–1 turn after it bottoms.
- 6 Top up with engine oil, start the engine and let it run for 20-30 seconds.
- 7 Stop the engine, check the oil level and top up as required.
- 8 Check the sealing round the oil filters.

## Fuel System

### **⚠ WARNING!**

Fire hazard. When carrying out work on the fuel system make sure the engine is cold. A fuel spill onto a hot surface or an electrical component can cause a fire. Store fuel soaked rags so that they cannot cause fire.

Store fuel-soaked rags so that they cannot cause fire.

### **IMPORTANT:**

Always observe the greatest cleanliness during refueling and work on the fuel system. Only use the grades of fuel recommended in the fuel specification.

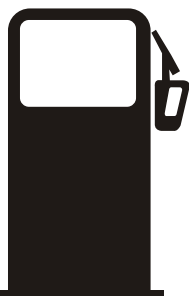

P0002101

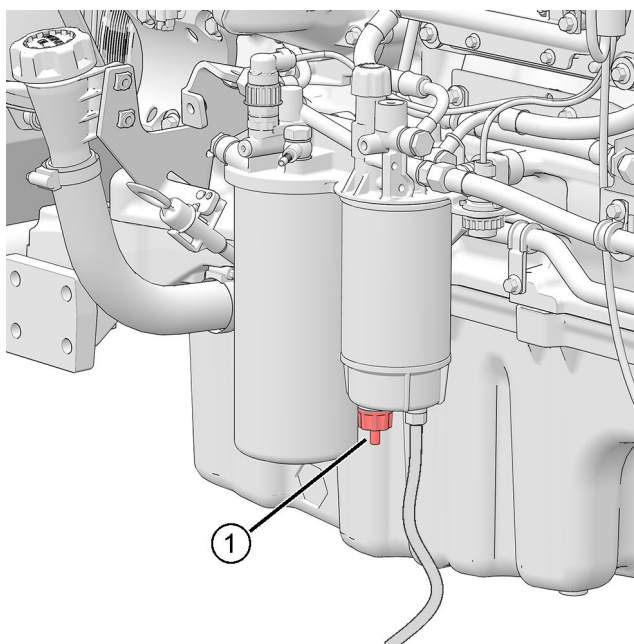

## Draining condensate, fuel system

- 1 Put a collection vessel under the fuel filter to collect the condensate and fuel.
- 2 Open the drain nipple (1) in the base of the fuel pre-filter.
- 3 Tighten the drain tap (1) when fuel without water starts to run out.

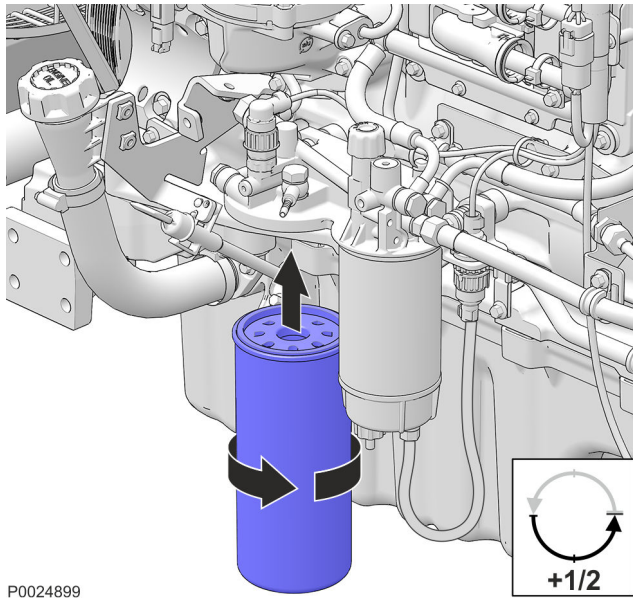

P0024899

## Engine Fuel Filter Replacement

The fuel filter shall be replaced while the engine is cold.

### **⚠ WARNING!**

Fire hazard. When carrying out work on the fuel system make sure the engine is cold. A fuel spill onto a hot surface or an electrical component can cause a fire. Store fuel soaked rags so that they cannot cause fire.

Do not fill the new fuel filter with fuel before assembly. There is a risk that contamination could get into the system and cause malfunctions or damage.

- 1 Clean round the fuel filter.
- 2 Remove the filter with a suitable filter remover. Collect any spilled fuel in a collection vessel.
- 3 Clean the filter mating surface on the filter bracket.
- 4 Lubricate the seal with diesel fuel and install the new fuel filter. Tighten the fuel filter in accordance with the instructions on the fuel filter.
- 5 Where necessary, bleed the fuel system; refer to *Fuel system, bleeding, page 64*.
- 6 If a water trap is installed, change the filter in it at the same time as the fuel filter, and clean the water trap in the plastic bowl under the filter with a soft rag.



## Fuel Pre-filter, Change

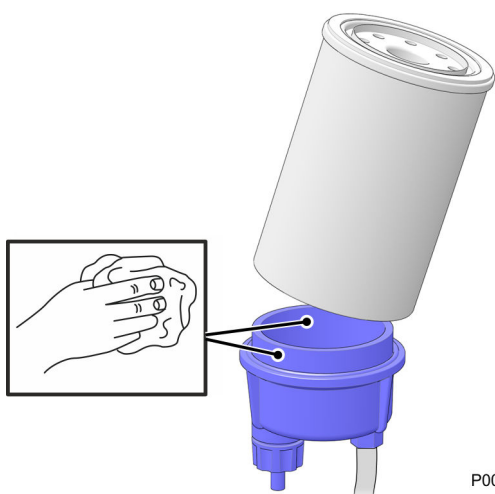
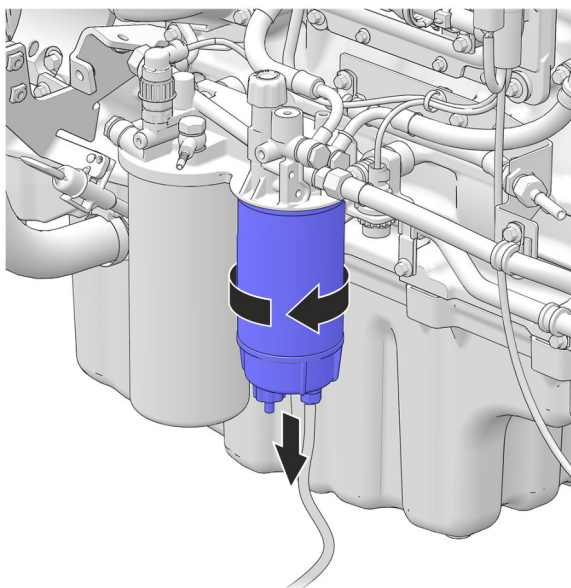
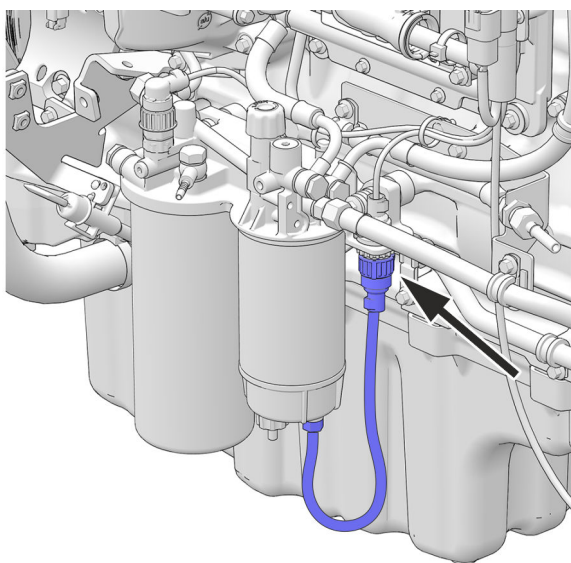

P0025625

- 1 Undo the cable from the water trap sensor.
- 2 Remove the water trap filter from the filter bracket. Collect any spilled fuel in a collection vessel.
- 3 Remove the lower part of the water trap from the filter.
- 4 Clean the lower part of the water trap with a soft rag. Check that the drain hole in the lower part is not blocked.
- 5 Install a new seal on the lower part and lubricate the seal with diesel fuel. Re-install the lower part of the filter.
- 6 Lubricate the seal with diesel fuel. Screw the filter onto the filter bracket by hand until the rubber seal just touches the mating surface. Then tighten a further half turn, no more.
- 7 Connect the cable to the water trap sensor.
- 8 Where necessary, purge the fuel system; refer to *Bleeding the Fuel System*.

## Fuel system, bleeding

Check that there is sufficient fuel in the tank, and that any fuel taps are open.

**NOTICE!** Be prepared to gather up fluid.

- 1 Release the hand pump on the fuel filter bracket by pushing and twisting the plastic handle..

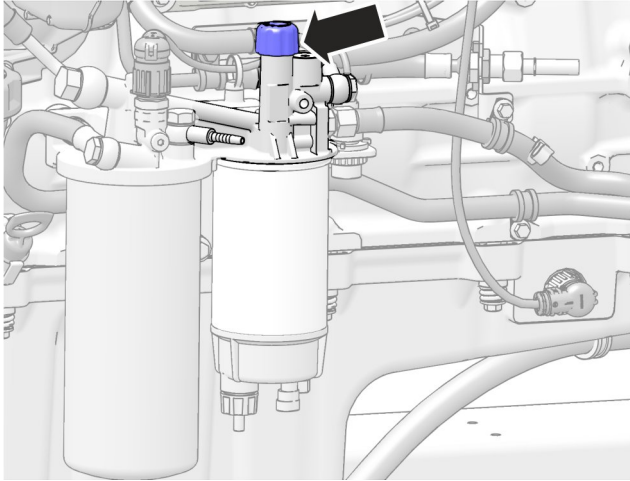

P0019904

- 2 Open the nipple on the front fuel connection. Connect a drain hose.

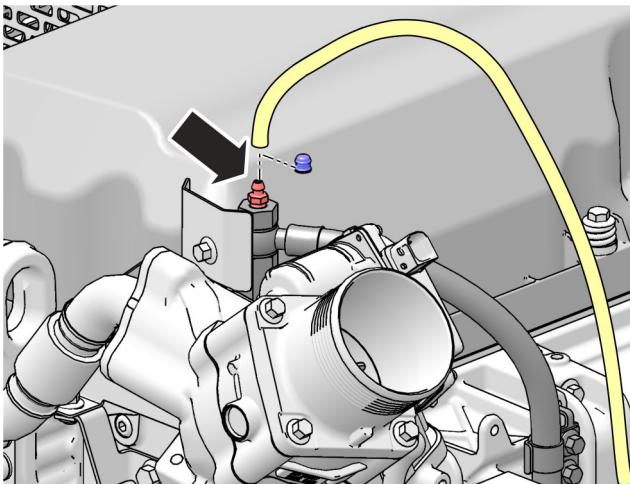

P0019905

- 3 Purge the fuel system by pumping with the hand pump until fuel flows.

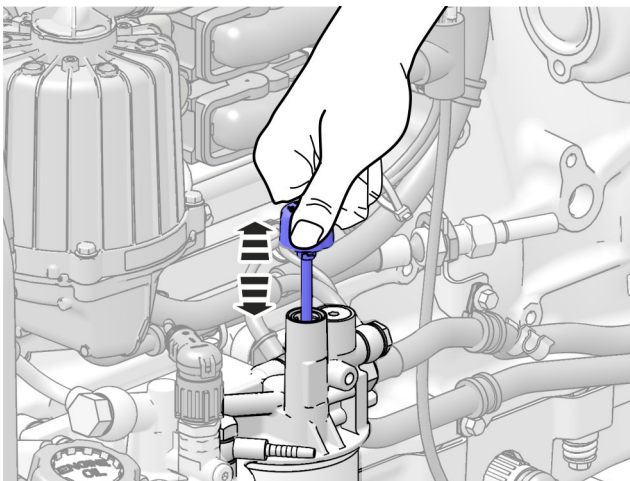

P0019889

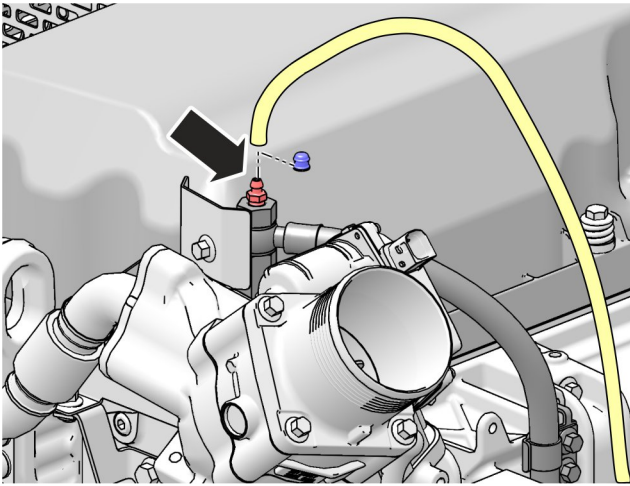

P0019905

- 4 Close the venting nipple and remove the drainage hose.

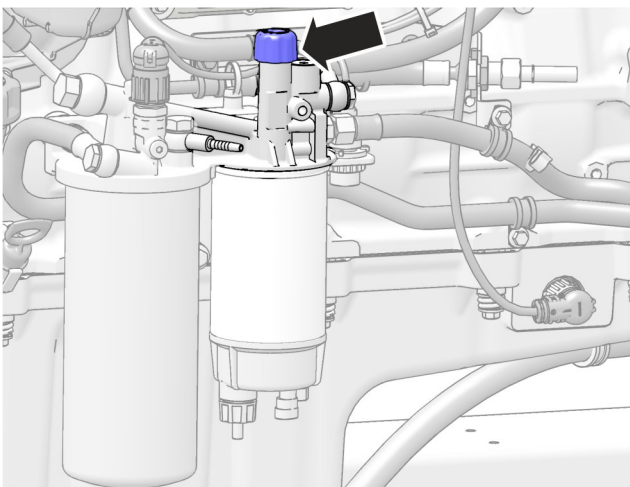

P0019904

- 5 Secure the hand pump.
- 6 Start the engine and allow it to idle for about 10 minutes.
- 7 Perform a leakage and function check.



P0013077

## Cooling System

The cooling system ensures that the engine operates at the correct temperature. It is a closed system that should always be filled with a coolant mixture.

### **IMPORTANT:**

Coolant of a suitable chemical composition must be used all year round to protect the engine against internal corrosion, cavitation and freeze bursting. This even applies when there is no risk for freeze damage, to make sure the engine always has a complete corrosion protection.

Therefore, the use of anti-corrosion agents alone, or water alone as a coolant, is not permitted in Volvo Penta engines.

The coolant must be based on Organic Acid Technology (OAT). Using an improper coolant or mixing with another coolant will rapidly reduce the performance and lifetime of the engine. Material incompatibility can lead to leakages, which - in the worst case - can cause engine breakdown.

Volvo Penta strongly recommend the use of our own coolants, "Volvo Penta Coolant VCS Ready Mixed" or the concentrate "Volvo Penta Coolant VCS", which ensure the protection of the cooling system components from corrosion, ageing, swelling and cracking, thereby ensuring optimal engine lifetime.

Over time the corrosion protection additives become less effective, and consequently the coolant must be changed at regular intervals to maintain sufficient protection of the engine. The latest Service Protocol that specifies service intervals can be found at [volvopenta.com](http://volvopenta.com).

### **Coolant, Mixing**

It is extremely important that the system is filled with the correct coolant concentration; refer to *Coolant, Mixing, page 86*.

The coolant should be mixed with distilled, deionized water. For Volvo Penta specified water requirements; refer to *Coolant, Mixing, page 86*.

**NOTICE!** If water quality can not be guaranteed, use ready mixed coolant.

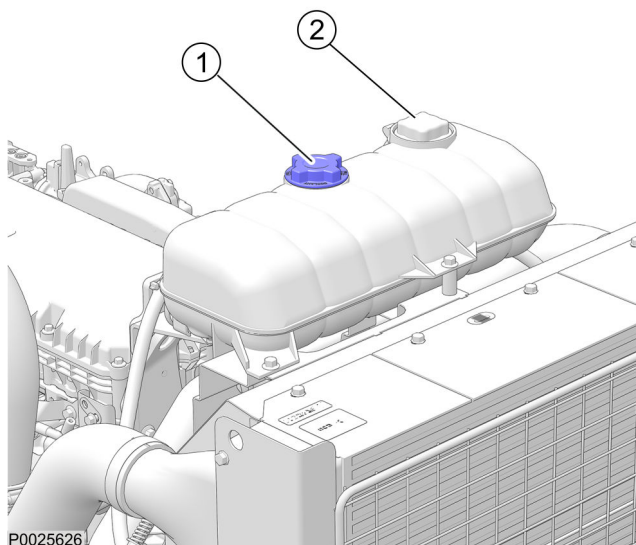

P0025626

## Coolant Level, Checking and Topping Up

Coolant filling must be performed with the engine stopped. Check the coolant level daily before starting.

### IMPORTANT:

Only use coolant recommended by Volvo Penta. Top up with the same type of coolant as already used in the system. Different types of coolant must not be mixed.

### ⚠ WARNING!

Do not open the coolant filler cap when the engine is hot, except in emergencies as this could cause serious personal injury. Steam or hot fluid could spray out.

- 1 Only open the filler cap (1). Do not open the pressure cap (2).
- 2 Check that the coolant level is above the MIN mark on the expansion tank.
- 3 Top up with coolant as required, so that the level is between the MIN and MAX marks. Fill slowly, to allow air to flow out.

### Filling a completely empty system

**NOTICE!** Mix the correct amount of coolant in advance, to ensure that the cooling system is completely filled. Refer to Technical Data, Cooling System, for the correct coolant volume.

Do not open the pressure cap (2).

- 1 Check that all drain points are closed.
- 2 Open filler cap (1).
- 3 Fill with coolant, so that the level is between the MIN and MAX marks. Fill slowly, to allow air to flow out.

**NOTICE!** Do not start the engine until the system is completely filled and bled.

- 4 Start the engine when the cooling system has been completely filled and bled. Open any bleeding nipples a short while after starting, to allow trapped air to escape. If a heating unit is connected to the engine cooling system, the heat control valve must be opened and the installation vented during filling.
- 5 Stop the engine after about an hour and check the coolant level. Top up as necessary.

## Coolant, Draining

### **⚠ WARNING!**

Do not open the coolant filler cap when the engine is hot, except in emergencies as this could cause serious personal injury. Steam or hot fluid could spray out.

### **IMPORTANT:**

The coolant contains corrosion-inhibiting additives. Never drain the engine cooling system on engines, which are to be put in storage.

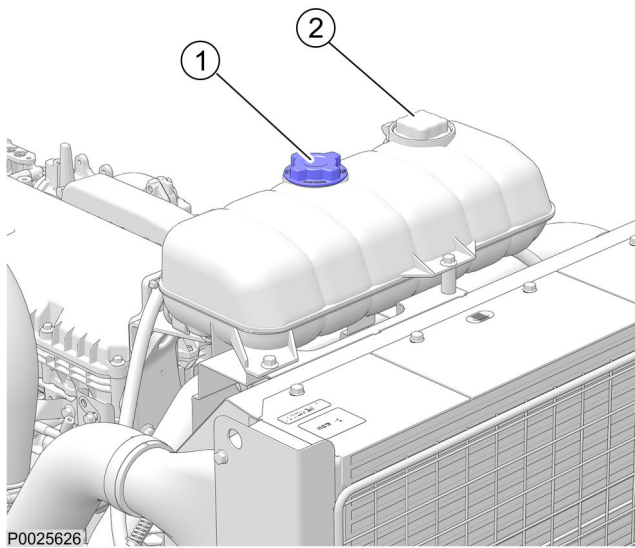

- 1 Stop the engine.
- 2 Remove the filler cap (1). Do not open the pressure cap (2).
- 3 Place a suitable vessel for the coolant to drain off into.
- 4 Open all drain points. Drain the coolant from the radiator and engine block, using the drain hose. The drain nipples are situated under the radiator on the right side of the engine block.
- 5 Check that all coolant drains out. Deposits may be found inside the drain plug/tap, and need to be cleared away. There is otherwise a risk that coolant could remain and cause damage due to freezing. Check whether the installation has any further taps or plugs at the lowest points of the cooling water pipes.
- 6 Shut any taps and check that the spring-loaded covers on the nipples close completely. Install the rubber plugs.

## Charge Air Cooler, External Cleaning

### **IMPORTANT:**

Do not use a high pressure power washer.

Remove guards as necessary, to access the radiator. Clean with water and a mild detergent. Use a soft brush. Be careful not to damage the radiator vanes. Reinstall removed parts.

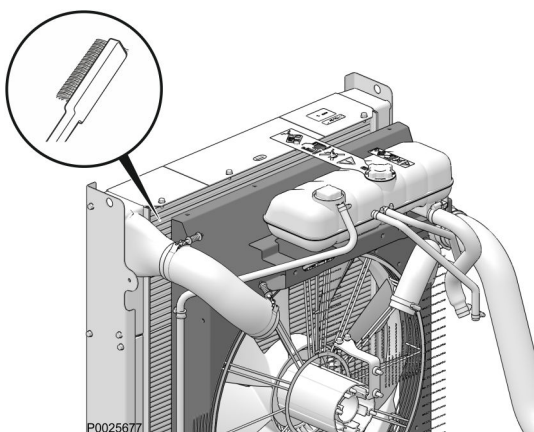

## Cooling System, Cleaning

### **WARNING!**

All coolant is hazardous and harmful to the environment. Do not consume. Coolant is flammable.

### **IMPORTANT:**

Never clean the cooling system if there is any risk of freezing, since the cleaning solution does not have any antifreeze properties.

### **IMPORTANT:**

It is extremely important that the correct concentration and volume of coolant is added to the system. Mix in a separate clean vessel before filling the cooling system. Make sure that the liquids mix.

### **IMPORTANT:**

Always follow local safety instructions and regulations.

Cooling performance is reduced by deposits in the radiator and cooling galleries. The cooling system should be cleaned out when the coolant is changed.

- 1 Empty the cooling system. Refer to *Coolant, Draining, page 68*.
- 2 Put a hose into the expansion tank filling hole and flush with clean water, as specified by Volvo Penta—refer to section Water quality in *Technical Data, page 86* until the water draining out is completely clear.
- 3 If there should still be some contamination left after flushing for a long time, cleaning can be done with coolant. Otherwise, continue as in item 8 below.
- 4 Fill the cooling system with 15-20 % mixture of concentrated coolant. Use only Volvo Penta recommended concentrated coolant mixed with clean water.
- 5 Drain the coolant after 1-2 days of operation. Remove the filler cap and possibly the lower radiator hose to increase the speed of emptying. To prevent suspended material from settling back in the system emptying should be done rapidly, within the space of 10 minutes, when the engine has not been standing still for a long time.
- 6 Flush the system immediately and thoroughly with clean hot water to prevent dirt from settling in the inner areas. Flush until the water that runs out is completely clean. Make sure that any heater controls are set to full heating during emptying.
- 7 If contamination should still be left after a long period of flushing, cleanout using Volvo Penta radiator cleaner, followed by finishing-off with Volvo Penta neutralizer. Carefully follow the instructions on the package. Otherwise, continue as in item 8 below.
- 8 When the cooling system is completely free from contamination, close the drain taps and plugs.

- 9 Fill up with Volvo Penta recommended coolant, following the instructions in the chapters entitled *Maintenance, page 66* and *Coolant Level, Checking and Topping Up, page 67*.



## Inlet and Exhaust System

### Filling AdBlue®/DEF

#### ⚠ CAUTION!

AdBlue®/DEF spilt onto hot components will quickly vaporize. Turn your face away!

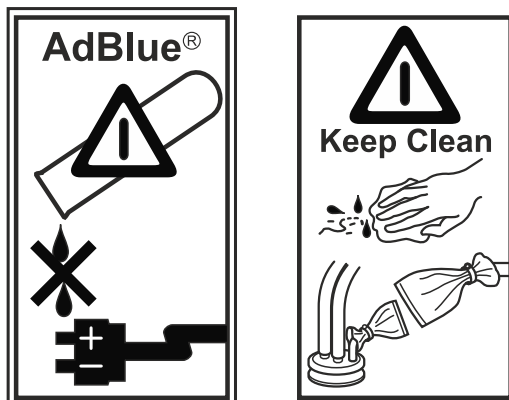

P0011697

#### ⚠ CAUTION!

Risk of corrosive damage.  
Contact with the fluid can cause irritation and corrosion.  
Wear protective gloves!  
Change gloves and clothing that have been in contact with the liquid.

#### ⚠ CAUTION!

Risk of material damage.  
AdBlue®/DEF oxidises metal and the capillary action creeps through lines at a speed of approx. 0.6 metres per hour.  
If spillage occurs, electrical connectors must be replaced immediately. Do not try to clean with water or compressed air.

#### IMPORTANT:

Dirt/dust, oil, greases, detergents and any chemicals and natural products must be prevented from entering the Adblue/DEF tank.

The system will be damaged if dust or dirt enters the tank clogging the filters in the dosing system.  
Keep the tank clean at all times.

#### IMPORTANT:

Never start the engine if anything other than clean AdBlue®/DEF has been added to the tank.

#### IMPORTANT:

The use of solution that do not fulfill the ISO 22241 standard will compromise the aftertreatment system performance, increase emissions.  
Any warranty claims will be rejected.



P0024301

When topping off AdBlue®/DEF a nozzle with a built-in shut-off function should be used in accordance with ISO standard 22241. These nozzles are designed not to fit any other filling equipment.

The tank cover is blue and marked with the text 'AdBlue/DEF only' to avoid confusion when filling. The ratio between the consumption of Adblue®/DEF and diesel is dimensioned as at least 1:1 to avoid the solution's running out before the diesel.

Never fill with AdBlue®/DEF other than ISO 22241 as specified by Volvo.

If this instruction is not followed the aftertreatment system may be permanently damaged. Engine power may also be affected negatively and engine components risk damage. Damage and costs arising from a failure to meet these requirements are not covered by Volvo Penta warranty obligations.

If AdBlue®/DEF is filled from a can or pump that lacks a stop function, it is important to make sure the tank is not overfilled as the solution may leak out of the breather tube. If the tank is overfilled and the solution in it freezes at temperatures below -1 °C (12.2 °F), the tank and the hoses may be permanently damaged.

Take great care not to spill the solution as it is extremely corrosive toward many materials. If a spill should occur the solution must be absorbed using dry sand or other non-flammable material and handled according to local and national regulations. Avoid spills onto soil and into waterways.

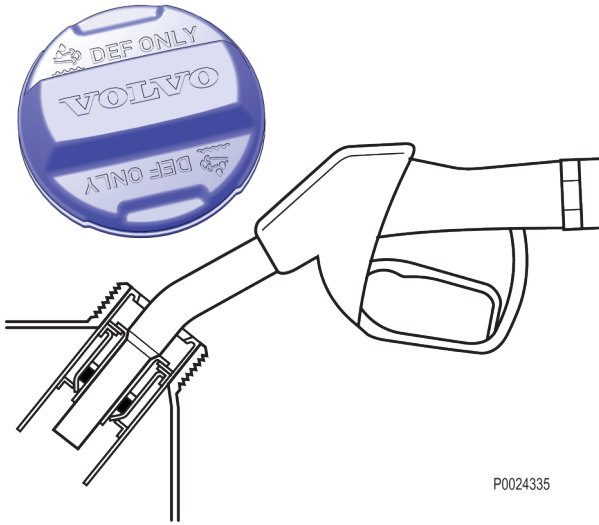

P0024335

## Erroneous filling of diesel or AdBlue®/DEF

**IMPORTANT:**

The filling of diesel or AdBlue®/DEF in the wrong tank can result in damage to the engine.

In order to avoid confusion, the AdBlue®/DEF tank has a blue filler cap and a decal affixed to the tank.

**Mistaken filling of AdBlue®/DEF in the diesel tank**

- The engine will not run at full power or will not run at all
- Injectors may be damaged
- Corrosion in the exhaust system between the turbocharger and aftertreatment system
- Expensive repairs

**Mistaken filling of diesel in the AdBlue®/DEF tank**

- The aftertreatment system may be seriously damaged
- The engine will no longer fulfill emission level requirements
- Expensive repairs

## AdBlue/DEF-Pump Filter, Change

**NOTICE!** Emission-related component.

- 1 Stop the engine.

**NOTICE!** Wait until the pump unit has stopped running as it usually performs automatic emptying of the AdBlue®/DEF hoses.

- 2 Disconnect the battery negative terminal.

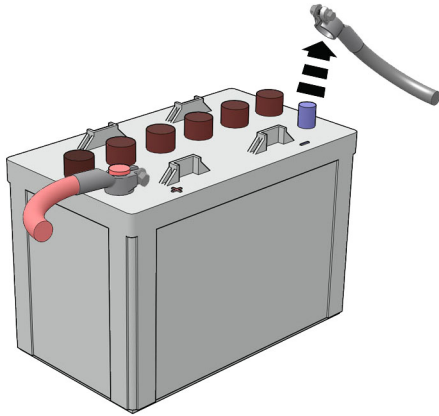

P0019364

- 3 Place a collection vessel under the filter cover.

**NOTICE!** Use approved safety equipment and collection vessel.

- 4 Undo the filter cover

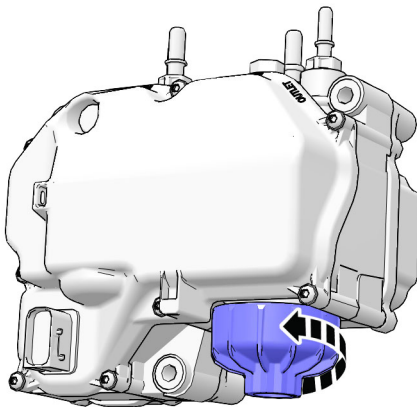

P0019389

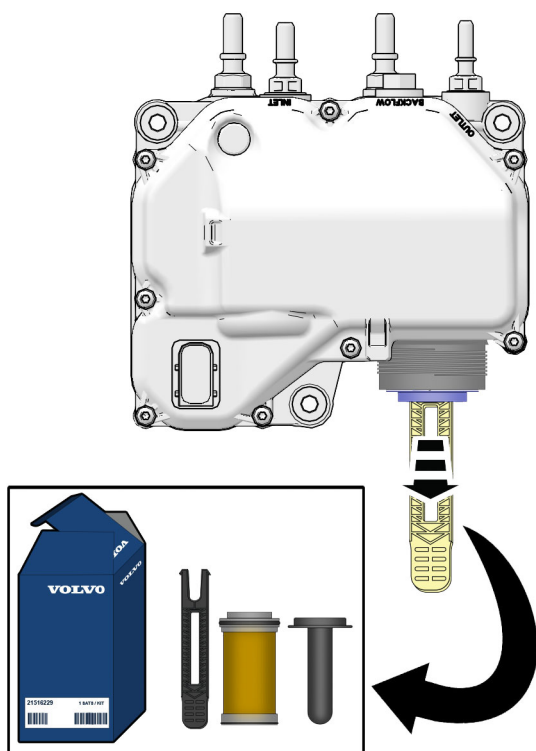

P0019390

- 5 Use the puller (supplied with the filter kit) to pull out the filter by first pressing it into the filter hole until it clicks.
- 6 Pull out the filter.

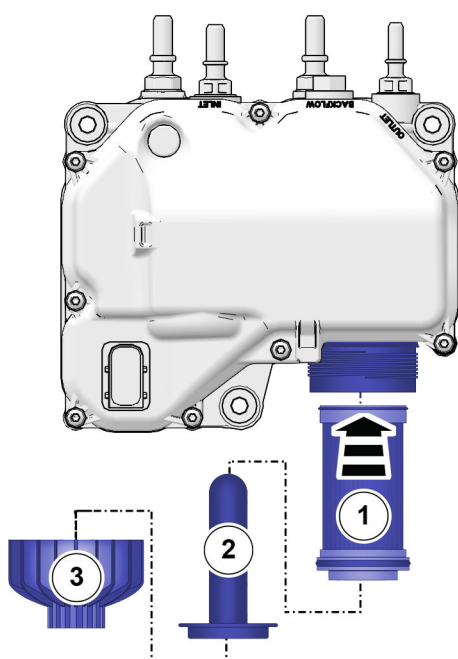

P0019391

- 7 Install the new filter (1).  
Install the rubber gasket (2).  
Screw on the filter cover (3).

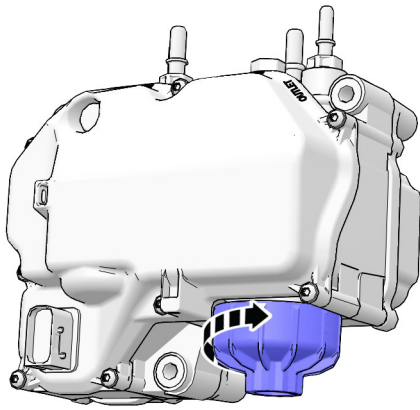

- 8 Tighten the cover.  
**Tightening torque: 20 (+5) Nm (14.8 +3.68 lbf. ft.)**

P0019392

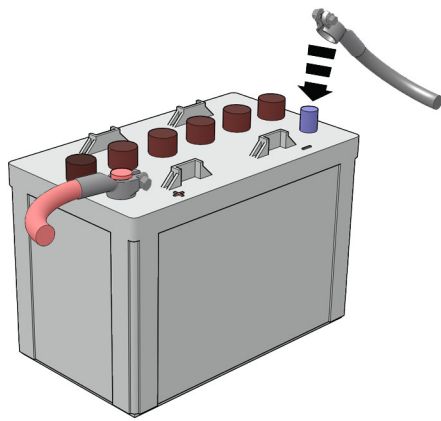

- 9 Reconnect the battery negative terminal.
- 10 Start the engine. Check for leaks; check function.
- 11 Delete any fault codes.

P0019365

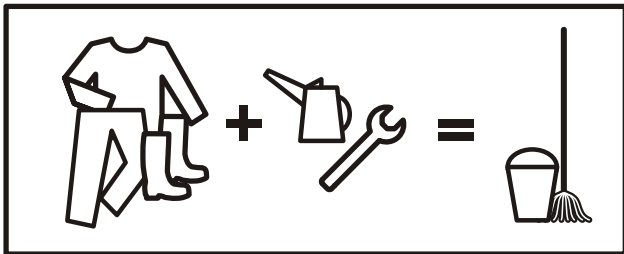

**NOTICE!** Care for equipment and the remaining AdBlue®/DEF.

p0013225

## Electrical System

The engine is equipped with a 2-pole electrical system and an alternator.

### **⚠ WARNING!**

Always stop the engine and break the current using the main switches before working on the engine.

### **IMPORTANT:**

Contact a Volvo Penta dealer for information if any arc welding will be performed on the application.

Arc welding can cause damage to the engine and the electronics.

## Main switch

### **IMPORTANT:**

Never disconnect the current using the main switches when the engine is running or by disconnecting the battery cables.

The alternator and electronics could be damaged.

The main switches must never be switched off before the engine has stopped. If the circuit between the alternator and the battery is disconnected when the engine is running, the alternator and electronics may be damaged. For the same reason, the charging circuits must never be re-connected with the engine running.

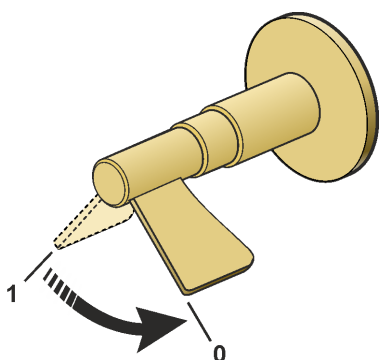

P0002576

## Fuses

The engine is equipped with two fuses which cuts the current if overloaded. There is one for the engine (15 A) and one for the ETAS system (25 A).

The engine stops if the fuse trips. If the fuse trips frequently, Volvo Penta recommends that a qualified workshop should be contacted to investigate the cause of the overload.

Refer to *Maintenance*, page 54 for location of the fuses.

## Electrical Connections

Check that electrical connections are dry, free from oxide, and that they are securely tightened.



P0002107

## Battery

### ⚠ WARNING!

Risk of fire and explosion. Never allow an open flame or electric sparks near the batteries.

### ⚠ WARNING!

Battery electrolyte is a corrosive acid and should be handled with care. If you spill or splash electrolyte on any part of the body, immediately flush the exposed area with liberal amounts of water and seek medical attention as soon as possible.

### ⚠ WARNING!

Ventilate the engine compartment before working on batteries or battery connections.

### IMPORTANT:

Batteries can be damaged if they are left discharged, and can also freeze and burst easier in cold weather. If the engine is not going to be used for a longer period of time, the batteries should be fully charged, trickle charged if possible.

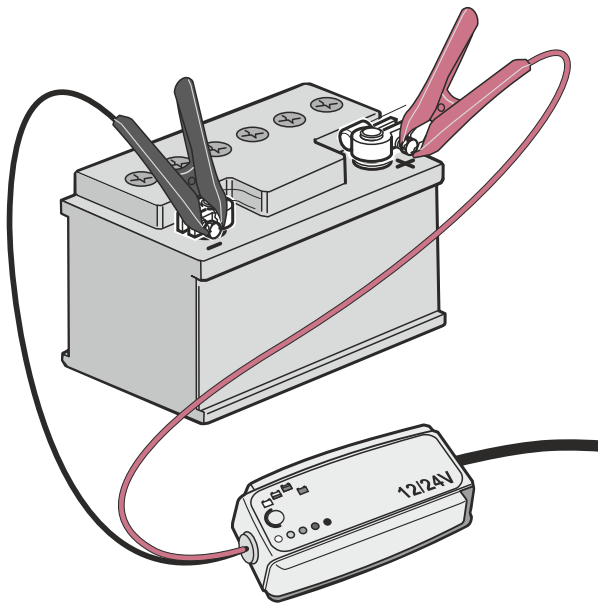

P0022892

## Maintenance

It is important to always follow the battery manufacturer's recommendation and instruction when replacing and charging batteries. Depending on battery type, the instructions for maintenance and charging may vary.

Modern batteries are normally maintenance free, but there are some actions that are recommended to increase the battery service life and avoid accidents:

- Keep the batteries clean and dry. Contamination and oxide on the batteries and battery poles can result in stray currents, voltage drop and discharge, especially in wet weather.
- Remove oxidation from the battery poles and terminals, using a brass brush.
- Tighten the terminals securely and grease them with terminal grease or petroleum jelly. Loose battery connections may cause damage to the engine's electrical system.
- Charge the battery regularly. A battery that is kept fully loaded has a maximum service life. The easiest way to check if a battery needs charging is to use a voltmeter.



## Replacing Battery

### IMPORTANT:

Make sure that the new battery fulfills the specifications in *Technical Data*. Read the information supplied with the battery before you begin the installation.

### IMPORTANT:

Do not disconnect the batteries with the engine running.

Sensitive electrical components can be immediately damaged.

### ⚠ WARNING!

Never confuse the positive and negative poles on the batteries. Risk of arcing and explosion.

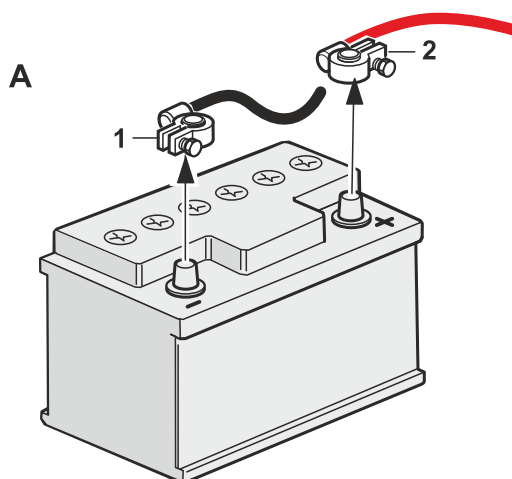

### Disconnecting (A)

- 1 Untighten the nut and remove the – cable (black).
- 2 Untighten the nut and remove the + cable (red).

Remove the battery.

### Connecting (B)

Place the new battery.

- 1 Connect the + cable (red) to the + pole on the battery and tighten the nut.
- 2 Connect the – cable (black) to the – pole on the battery and tighten the nut.

**NOTICE!** Hand in the old battery to a re-cycling station.

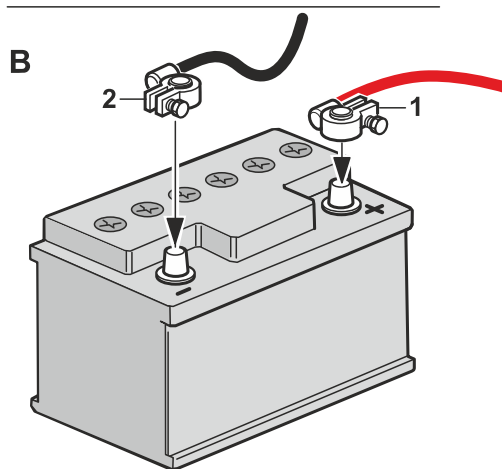

P0022893

# Storage

To prevent the engine and other equipment from being harmed during long (2 months or more) periods out of service, it must be conserved. Conservation protects the engine from freezing and corrosion damages.

It is of utmost importance that the conservation is performed correctly, therefore we have compiled a checklist covering the most important points. Before taking the engine out of service for long periods, Volvo Penta recommends that the engine is checked by a qualified workshop for possible need for overhaul or repair.

## ⚠ CAUTION!

Read the chapter on Maintenance in the Operator's Manual before starting work. It contains instructions on how to carry out maintenance and service operations in a safe and technical correct manner.

## ⚠ WARNING!

Conservation oils can be flammable and dangerous to inhale. Ensure good ventilation. Use a protective face mask when spraying.

## IMPORTANT:

Washing with a power washer: Never aim the water jet at radiators, charge air cooler, seals, rubber hoses or electrical components.



P0002089

- **For up to 8 month's stoppage:**  
Change the oil and oil filter on the engine, then run the engine until warm.
- **More than 8 month's stoppage:**  
Conserve the lubrication and fuel systems with conservation oil. Refer to the section *Conservation of the lubrication and fuel systems for more than 8 months' stoppage*.
- Make sure the coolant has adequate antifreeze properties. Top up as necessary. Alternatively, you can drain the coolant (also drain the coolant filter).
- Drain any water and contamination from the fuel filters and fuel tank. Fill the fuel tank completely, to avoid condensation.
- Disconnect the battery cables, clean and charge the batteries. Trickle charge the batteries while the equipment is in storage. **A poorly charged battery can freeze and burst.**
- Clean the outside of the engine. Do not use a high pressure washer for engine cleaning. Touch up paint damage with Volvo Penta original paint.
- Put a note on the engine with the date, type of conservation and the conservation oil used.
- Cover the air filter, exhaust pipe and engine if necessary.
- Empty the AdBlue/DEF tank and rinse it with distilled water.

## Bringing Out of Storage

- Remove any covers from the engine, air filter and exhaust pipe.
- Fill the engine with the correct grade of oil into the engine, as necessary, refer to *Technical Data, Lubrication System*. Install a new oil filter if the filter was not changed during conservation.
- Install new fuel filters and bleed the fuel system.
- Check the drive belt(s).
- Check the condition of all rubber hoses, and retighten the hose clamps.
- Close the drain taps and install any drain plugs.
- Check the coolant level. Top up as necessary.
- Connect the fully charged batteries.
- Start the engine and warm it up at fast idle with no load.
- Check that no oil, fuel or coolant leakage occurs.
- Fill the AdBlue/DEF tank. The solution must fulfill ISO 22241 standards.

## Conservation of the lubrication and fuel systems for more than 8 months' stoppage:

- Drain the engine oil and fill up with **conservation oil\*** to just over the MIN marking on the dipstick.
- Connect the fuel suction and return hoses to a 1/3 full jerrican containing **conservation oil\*** and 2/3 diesel fuel.
- Bleed the fuel system.
- Start the engine and run at a fast idle until about 2 liters (0.6 US gal) of the fluid in the jerrican have been used. Stop the engine and re-connect the fuel suction and return lines.
- Drain the conservation oil from the engine.
- Follow the other instructions on the previous page.

\* Conservation oils are sold by oil companies.

# Technical Data

## Engines

<b>Type designation</b>	<b>TAD1170VE, TAD1171VE, TAD1172VE</b>
Power, prime/stand-by	Refer to the sales literature
Torque, Prime/Standby	Refer to the sales literature
No. of cylinders	6
Bore	123 mm (4.84 inch)
Stroke	152 mm (5.98 inch)
Displacement	10,84 dm <sup>3</sup> (661 in <sup>3</sup> )
Weight, wet (Engine)	1072 kg (2363 lb)
Firing order	1-5-3-6-2-4
Compression ratio	17.0:1
Idling speed	600–900

## Lubrication System

<b>Oil</b>	
Oil capacity including oil filters, approx.:	37 liters (9.77 US gal)
<b>Oil Sump</b>	
Minimum	27 liters (7.0 US gal)
Maximum	32 liters (9.45 US gal)
<b>Oil pressure, hot engine</b>	
at operating speed	350-600 kPa (51-87 psi)

### Oil recommendations

Oil quality	Service interval, reached first in operation
VDS-3, VDS-4	<b>1000</b> hours or 12 months

**NOTICE!** Sulfur content in fuel must not exceed 15 ppm.

**NOTICE!** Mineral-based oil, either fully or semi-synthetic, can be used on condition that it complies with the quality requirements above.

VDS = Volvo Drain Specification

## Viscosity

Select the viscosity according to the table.

The temperature values refer to stable ambient temperatures.

\* SAE 5W/30 refers to synthetic or semi-synthetic oils.

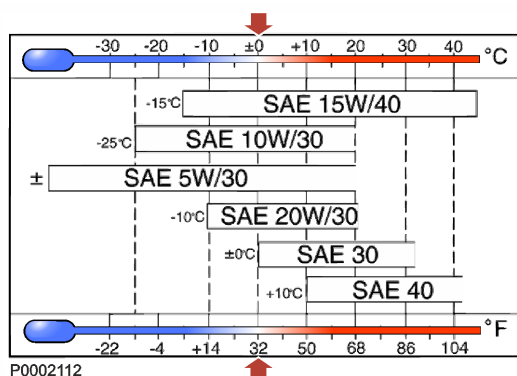

## Fuel System

<b>Feed pump</b>	
Feed pressure at 900 rpm	min 100 kPa (14.5 psi)
Feed pressure at 1800 rpm	min 300 kPa (43,5 psi)
Feed pressure at full load	min 300 kPa (43,5 psi)
<b>Bypass valve</b>	
Opening pressure	400-550 kPa (58–80 psi)

### Fuel quality requirements for diesel engines with aftertreatment system

#### General requirements

Volvo Penta diesel engines are certified for compliance with emission legislations with the diesel test fuels specified by law. These fuels correspond with diesel fuel standards EN 590, ASTM D975, JIS K2204 and paraffinic diesel fuel standard EN 15940. Volvo Penta guarantees compliance with emission legislation and fulfillment of expected lifetime as long as the specified restrictions are followed.

It is the responsibility of the fuel suppliers to always ensure that their fuels meet relevant requirements and are fit for their intended purpose. Their responsibility includes any use of additives for proper engine performance and function.

Special requirements are placed on cold-flow properties, that is, temperature limit values of fuel filterability during operation in winter conditions.

#### Restrictions for specified diesel fuels

- **Max density for ASTM D975 No 2-D: 860 kg/m<sup>3</sup>**  
Insufficient density reduces the power and increases the fuel consumption. Excessive density endangers the durability and function of the fuel injection equipment.
- **Max lubricity (wsd 1.4) for JIS K 2204: 460 μm**  
Sufficient fuel lubricity is essential to protect the fuel injection system against excessive wear.

#### Restrictions for other diesel fuels

Volvo Penta also approves the use of other diesel fuels as long as the here specified restrictions are followed. However Volvo Penta does not guarantee compliance with emission legislation or fulfillment of expected lifetime with these other diesel fuels.

**NOTICE!** Operators must check permission for usage of these fuels according to regional, national or local regulations.

- **Min cetane number: 40**  
An insufficient cetane number (“ignitability”) leads to poor startability and increased exhaust emissions.
- **Max density at 15 °C: 860 kg/m<sup>3</sup>**  
Insufficient density reduces the power and increases the fuel consumption. Excessive density endangers the durability and function of the fuel injection equipment.
- **Viscosity between 1.9 to 4.6 mm/s<sup>2</sup> at 40 °C**  
Insufficient viscosity reduces the power and increases the fuel consumption. Excessive viscosity endangers the durability and function of the fuel injection equipment.
- **Max lubricity (wsd 1.4): 520 μm**  
Sufficient fuel lubricity is essential to protect the fuel injection system against excessive wear.
- **Max FAME (biodiesel) content: 10% (V/V)**  
FAME is blended into diesel fuel, excessive FAME content damage the catalytic system.
- **Max sulfur content: 15 mg/kg**  
Excessive sulfur content damage the catalytic system.

**Paraffinic fuels - HVO and GTL**

Paraffinic diesel fuels (“Synthetic Diesel”) have higher cetane numbers and lower densities than diesel fuels. HVO (Hydrotreated Vegetable Oils) is renewable paraffinic fuels. GTL (Gas-To-Liquid) is fossil paraffinic fuels.

Volvo Penta approves the use of paraffinic diesel fuels that complies with standard EN 15940. The fuel guarantees compliance with emission legislation and fulfills the expected lifetime as long as the service requirements are followed.

Volvo Penta also approves the use of fuel blends between these paraffinic fuels and diesel fuels that comply with the quality requirements.

**Service requirements**

- When shifting from diesel fuel to paraffinic fuel, the fuel hoses and sealings must be replaced.

## Cooling System

Type	Pressurized, sealed
Pressure cap, max opening pressure	70 kPa (10.2 psi)
<b>Coolant</b>	
Volume (engine)	20 liters (5.28 US gal)
Volume (engine with standard radiator and hoses)	
Radiator, standard	44 liters (11.6 US gal)
Radiator, HD (Heavy Duty)	58 liters (15.3 US gal)
<b>Thermostat</b>	
Qty	1 pc
Opening temperature	82°C (180°F)



P0013077



P0002463

### Coolant, Mixing

**⚠ WARNING!**

All coolant is hazardous and harmful to the environment. Do not consume. Coolant is flammable.

**IMPORTANT:**

Always use the same type of coolant that is already in the engine.

Different types of coolant must not be mixed with each other.

Risk of reduced cooling function and performance by clogging and isolation.

**Coolant shall be based on Organic Acid Technology (OAT).**

**Follow the mixing recommendation on the product.**

The coolant should be mixed with distilled, deionized water. For Volvo Penta specified water requirements; refer to *Water Quality, page 87*.

**NOTICE!** Always use “Ready Mixed” coolant if water quality cannot be determined or if it does not fulfill ASTM D4985.

**NOTICE!** Never mix more than 60% concentrated coolant with water. A greater concentration provides reduced cooling effect with the risk for overheating and reduced freeze protection.



## Water Quality



P0002094

### ASTM D4985:

Total solid particles	<340 ppm
Total hardness	<9,5° dH
Chloride	<40 ppm
Sulfate	<100 ppm
pH value	5.5–9
Silica (acc. ASTM D859)	<20 mg SiO <sub>2</sub> /l
Iron (acc. ASTM D1068)	<0.10 ppm
Manganese (acc. ASTM D858)	<0.05 ppm
Conductivity (acc. ASTM D1125)	<500 µS/cm
Organic content, COD <sub>Mn</sub> (acc. ISO8467)	<15 mg KMnO <sub>4</sub> /l

## Inlet and Exhaust System

Tank	Small	Medium	Large	X Large
Usable volume	17.4 liters (4.54 US gal)	38.6 liters (10.2 US gal)	68 liters (17.96 US gal)	164.2 liters (43.38 US gal)

## Electrical System

System voltage	24 V		
Batteries	2 pcs. series connected		
Battery voltage	12 V		
Max. Battery capacity	2 x 225 Ah		
<b>Alternator</b>			
Max output at 27 V, ambient temperature 25 °C			
Engine speed	700 rpm	1200 rpm	1500 rpm
Alternator, 110 A	96 A	110 A	
Alternator, 150 A	130 A		150 A
Starter motor, Output	5,5 kW (7.4 hp)		
Battery electrolyte specific gravity at +25 °C:			
Fully charged battery	1.28 g/cm <sup>3</sup> (1.24 g/cm <sup>3</sup> )*		
Battery recharged at	1.20 g/cm <sup>3</sup> (1.20 g/cm <sup>3</sup> )*		

\* Note. Applies to batteries with tropical acid.

## Identification Numbers

**NOTICE!** The engine labels are placed on the valve cover.

- A Engine Designation
- B Specification number
- C Serial number (also stamped in engine block)
- D Engine power at operating speed

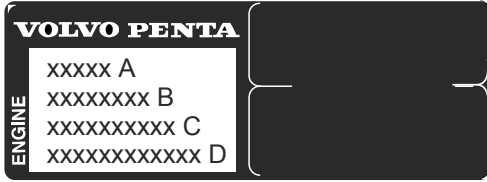

P0019329

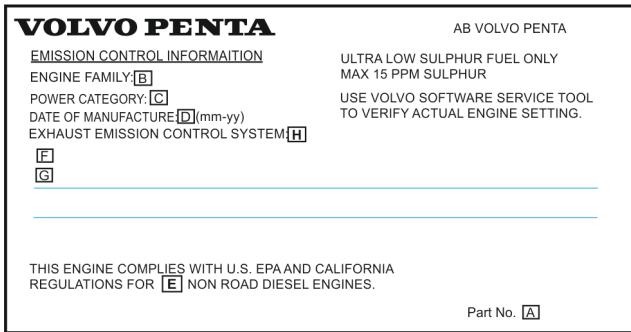

P0027408

- A. Label part number
- B. EPA Engine family
- C. Power Category
- D. Date of manufacturing
- E. Model Year
- F. >560KW Generator
- G. Constant Speed
- H. Exhaust Emission Control System



P0020083

Country of manufacture.

# VOLVO PENTA

Declaration for the installation of partially-completed machinery in accordance with  
Machinery Directive 2006/42/EC

## Engine Manufacturer:

AB Volvo Penta  
Gropegårdsgatan, SE 405 08 Gothenburg, Sweden

Description of engine 4-cycle diesel engine. Engine types covered by this declaration:

TAD540VE	TAD840VE	TAD940VE	TAD1140VE	TAD1340VE	TAD1341GE	TAD1640VE-B	TAD1640GE
TAD541VE	TAD841VE	TAD942VE	TAD1141VE	TAD1341VE	TAD1342GE	TAD1641VE	TAD1641GE
TAD542VE	TAD842VE	TAD943VE	TAD1142VE	TAD1342VE	TAD1343GE	TAD1641VE-B	TAD1642GE
TAD550VE	TAD843VE	TAD950VE	TAD1150VE	TAD1343VE	TAD1344GE	TAD1642VE	TAD1650GE
TAD551VE	TAD850VE	TAD951VE	TAD1151VE	TAD1344VE	TAD1345GE	TAD1642VE-B	TAD1651GE
TAD552VE	TAD851VE	TAD952VE	TAD1152VE	TAD1345VE	TAD1350GE	TAD1643VE	TWD1643GE
TAD570VE	TAD852VE	TAD940GE	TAD1170VE	TAD1350VE	TAD1351GE	TAD1643VE-B	TWD1644GE
TAD571VE	TAD853VE	TAD941GE	TAD1171VE	TAD1351VE	TAD1352GE	TAD1650VE	TWD1645GE
TAD572VE	TAD870VE		TAD1172VE	TAD1352VE	TAD1353GE	TAD1650VE-B	TWD1652GE
	TAD871VE			TAD1353VE	TAD1354GE	TAD1651VE	TWD1653GE
	TAD872VE			TAD1360VE	TAD1355GE	TAD1660VE	TWD1663GE
	TAD873VE			TAD1361VE	TAD1371VE	TAD1661VE	TWD1672GE
				TAD1362VE	TAD1372VE	TAD1662VE	TWD1673GE
				TAD1363VE	TAD1373VE	TAD1670VE	
				TAD1364VE	TAD1374VE	TAD1671VE	
				TAD1365VE	TAD1375VE	TAD1672VE	

Fundamental health and safety requirements applied to, and fulfilled by, the above-mentioned engines are described in the following items in Annex I:

1.1.3, 1.1.5, 1.5.1, 1.5.2, 1.5.3, 1.5.4, 1.5.6, 1.5.13, 1.6.1, 1.6.2, 1.6.4, 1.7.1, 1.7.1.1, 1.7.1.2, 1.7.4, 1.7.4 and 1.7.4.3.

The relevant technical documentation is compiled as described in part B of Annex VII.

Relevant information concerning the partially completed machinery will be provided in suitable form upon justified requests from competent national authorities. The individual authorized to compile the relevant technical documentation is the signer of this declaration.

The harmonizing standards applied are:

EN ISO 12100–1: Safety of machinery – Basic concepts, general principles for design – Part 1: Basic terminology, methodology.

EN ISO 12100–2: Safety of machinery – Basic concepts, general principles for design – Part 2: technical principles.

EN 1679–1: Reciprocating internal combustion engines – Safety – Part 1: Compression ignition engines.

The partially completed machinery also complies with the following relevant Directive:

2014/30/EU – Electromagnetic Compatibility (EMC) Directive.

Applied standards: EN 61000–6–1, EN 6100–6–2, EN 61000–6–3, EN 61000–6–4, EN 12895, EN-ISO 14982 and EN 13309.

For engines equipped with the Volvo Penta Start/Stop System the responsibility for the functional safety of the system lies with the machine manufacturer performing the integration.

The engines covered by this declaration may not be put into operation before the completed machinery into which they are to be installed has been declared to conform with the provision of Machinery Directive 2006/42/EC.

## Name and function:

Jonas Holmberg, Laws and Regulation

(The identity of the individual authorized to sign on behalf of the engine manufacturer or the latter's authorized representative.)

## Signature and title:



Date and place of issue: (yyyy-mm-dd) 2016–12–20 Gothenburg

LR-31/16–01



A series of 25 horizontal dotted lines spanning the width of the page, providing a guide for handwriting practice.

<b>A</b>		<b>O</b>	
AdBlue/DEF-Pump Filter, Change.....	74	Oil Filter/By-pass Filter, Change.....	60
After Engine Shutdown.....	41	Oil level, checking and topping up.....	59
Air Filter, Check and Replace.....	55	Operation.....	28, 37
Alarms.....	37	Operation at low load.....	38
Alternator Belt, Replace.....	58	Orientation.....	54
Auxiliary Stop.....	41	Overview.....	25
<b>B</b>		<b>Q</b>	
Battery.....	78	Quality shortcomings and component defects.....	47
Before Engine Shutdown.....	40	<b>R</b>	
Before Starting.....	34	Reading the Instruments.....	37
<b>C</b>		<b>S</b>	
Charge Air Cooler, External Cleaning.....	68	Starting in Extreme Cold.....	35
Charge Air Pipe, Leakage Check.....	56	Starting the Engine.....	35
Coolant Level, Checking and Topping Up.....	67	Starting Using Auxiliary Batteries.....	36
Coolant, Draining.....	68	Stop the Engine.....	40
Cooling System.....	66, 86	<b>V</b>	
Cooling System, Cleaning.....	69	Viscosity.....	83
<b>D</b>		Volvo Penta Action Service.....	21
DCU II (Display Control Unit).....	30, 35, 42	Volvo Penta Dealer Network.....	20
Diagnostic Function.....	42	<b>W</b>	
Draining condensate, fuel system.....	61	Warning Symbols.....	46
Drive Belt and Alternator Belt, Inspection.....	56	Water Quality.....	87
Drive belt, change.....	57		
<b>E</b>			
EATS (Exhaust Aftertreatment System).....	24		
EATS Inducements.....	48		
EATS Warnings and Inducements.....	46		
Electrical Connections.....	77		
Electrical System.....	77, 87		
Emission Aftertreatment System.....	19		
EMS (Engine Management System).....	23		
Engine Fuel Filter Replacement.....	62		
Engine Oil, Change.....	59		
Engine, General.....	55		
Engines.....	22, 82		
Environmental care.....	17		
Erasing fault codes.....	43		
Excessive strain on a product and components.....	16		
<b>F</b>			
Fault Tracing.....	44		
Filling AdBlue®/DEF .....	71		
Fuel Pre-filter, Change.....	63		
Fuel System.....	61, 84		
Fuel system, bleeding.....	64		
Fuel, oils and coolant.....	15		
<b>I</b>			
Identification Numbers.....	88		
Inlet and Exhaust System.....	71, 87		
<b>L</b>			
Lubrication System.....	58, 83		
<b>M</b>			
Main switch.....	77		
Maintenance and replacement parts.....	16		
Maneuvering.....	38		
<b>N</b>			
Never Use Start Spray.....	36		



A series of 25 horizontal dotted lines spanning the width of the page, providing a guide for handwriting practice.

**ENG**

This Operator's Manual may be ordered in a different language free of charge up to 12 months after delivery, via internet.

<http://manual.volvopenta.com/coupon/>

If internet access isn't possible, please contact your Volvo Penta dealer.

**GER**

Diese Betriebsanleitung kann bis zu 12 Monate nach der Lieferung über Internet kostenlos in einer anderen Sprache bestellt werden.

<http://manual.volvopenta.com/coupon/>

Wenn Sie keinen Internet-Zugriff haben, kontaktieren Sie bitte Ihren Volvo Penta-Händler.

**FRE**

Ce manuel d'utilisation peut être commandé gratuitement sur Internet en différentes langues, jusqu'à 12 mois après la date de livraison.

<http://manual.volvopenta.com/coupon/>

Veuillez contacter votre Distributeur Volvo Penta si vous avez un problème d'accès à l'Internet.

**SPA**

El presente libro de instrucciones puede solicitarse en otro idioma diferente, libre de cargo, hasta 12 meses después de la entrega, mediante internet.

<http://manual.volvopenta.com/coupon/>

Si no se tiene acceso a internet, contacten al su concesionario Volvo Penta.

**ITA**

Il manuale per l'operatore può essere ordinato tramite Internet, in varie lingue e per consegna gratuita, entro 12 mesi dalla consegna del prodotto

<http://manual.volvopenta.com/coupon/>

Se l'accesso a Internet risulta impossibile, contattare la concessionaria Volvo Penta.

**SWE**

Denna instruktionsbok kan beställas via internet på ett annat språk gratis i upp till 12 månader efter leverans.

<http://manual.volvopenta.com/coupon/>

Kontakta din Volvo Penta-återförsäljare om du inte har tillgång till internet.

**DUT**

Dit instructieboek kan gratis via internet in een andere taal worden besteld tot 12 maanden na aflevering.

<http://manual.volvopenta.com/coupon/>

Als toegang tot het internet niet mogelijk is, neem dan contact op met uw Volvo Penta dealer.

**DAN**

Denne instruktionsbog kan bestilles gratis på et andet sprog via Internettet i op til 12 måneder efter leveringen.

<http://manual.volvopenta.com/coupon/>

Hvis det ikke er muligt at bestille via Internettet, bedes du kontakte din Volvo Penta forhandler.

**FIN**

Tämä käyttöohjekirja on tilattavissa Internetin kautta veloituksetta eri kielillä 12 kuukauden ajan toimituksen jälkeen.

<http://manual.volvopenta.com/coupon/>

Jos sinulla ei ole Internet-yhteyttä, ota yhteys lähimpään Volvo Penta jälleenmyyjään.

**POR**

Este Manual do Operador pode ser encomendada em idiomas diferentes isento de custos até 12 meses após entrega, via internet.

<http://manual.volvopenta.com/coupon/>

Se não for possível aceder à internet, contacte o seu concessionário Volvo Penta.

**GRC**

Το παρόν Βιβλίο Χρήσης μπορεί να παραγγελθεί δωρεάν σε άλλη γλώσσα μέχρι 12 μήνες μετά την παράδοση, μέσω διαδικτύου.

<http://manual.volvopenta.com/coupon/>

Εάν δεν είναι δυνατή η πρόσβαση στο ιαδίκτυο, παρακαλούμε επικοινωνήστε με το δικό σας αντιπρόσωπο της Volvo Penta.

**RUS**

Данное руководство по эксплуатации можно бесплатно заказать на другом языке по Интернету в течение 12 месяцев после доставки.

<http://manual.volvopenta.com/coupon/>

Если доступ к Интернету отсутствует, обратитесь к своему дилеру компании Volvo Penta.

**TUR**

Bu Kullanım Kılavuzu, teslimden 12 ay sonrasına kadar internet yoluyla ücretsiz olarak farklı bir dilde sipariş edilebilir.

<http://manual.volvopenta.com/coupon/>

İnternet mümkün değilse, lütfen Volvo Penta yetkili satıcınızla temas geçin.

**CHI**

本操作手册可通过互联网以不同的语言进行订购，交付后可免费使用达12个月。

<http://manual.volvopenta.com/coupon/>

如果无法访问互联网，请与沃尔沃遍达经销商联系。

**BZS**

Este Manual de operador pode ser encomendado em um idioma diferente, gratuitamente, até 12 meses após a entrega, via internet.

<http://manual.volvopenta.com/coupon/>

Caso o acesso à internet não for possível, contatar seu distribuidor Volvo Penta.

**JPN**

このオペレーターズ マニュアルの他言語版が、発行後最高12か月間、インターネットより無料で発注可能です。

<http://manual.volvopenta.com/coupon/>

インターネットにアクセスできない場合は、担当のボルボペンタディーラーまでご連絡ください。

**ARA**

من الممكن طلب دليل المشغل بلغة أخرى مجاناً عبر الإنترنت لفترة تصل إلى ١٢ شهراً من بعد التسليم.

[http:// manual.volvopenta.com/coupon](http://manual.volvopenta.com/coupon/)

إذا كان الوصول إلى الإنترنت غير متاح، فالرجاء الاتصال بوكيل Volvo Penta.

**VOLVO  
PENTA**

**AB Volvo Penta**  
SE-405 08 Göteborg, Sweden  
[www.volvopenta.com](http://www.volvopenta.com)

